

Microprocessor pH Analyzer



ROSEMOUNT® ANALYTICAL
FISHER-ROSEMOUNT™ Managing The Process Better.™

ESSENTIAL INSTRUCTIONS **READ THIS PAGE BEFORE PROCEEDING!**

Rosemount Analytical designs, manufactures, and tests its products to meet many national and international standards. Because these instruments are sophisticated technical products, you must properly install, use, and maintain them to ensure they continue to operate within their normal specifications. The following instructions must be adhered to and integrated into your safety program when installing, using, and maintaining Rosemount Analytical products. Failure to follow the proper instructions may cause any one of the following situations to occur: Loss of life; personal injury; property damage; damage to this instrument; and warranty invalidation.

- Read all instructions prior to installing, operating, and servicing the product. If this Instruction Manual is not the correct manual, telephone 1-800-654-7768 and the requested manual will be provided. Save this Instruction Manual for future reference.
- If you do not understand any of the instructions, contact your Rosemount representative for clarification.
- Follow all warnings, cautions, and instructions marked on and supplied with the product.
- Inform and educate your personnel in the proper installation, operation, and maintenance of the product.
- Install your equipment as specified in the Installation Instructions of the appropriate Instruction Manual and per applicable local and national codes. Connect all products to the proper electrical and pressure sources.
- To ensure proper performance, use qualified personnel to install, operate, update, program, and maintain the product.
- When replacement parts are required, ensure that qualified people use replacement parts specified by Rosemount. Unauthorized parts and procedures can affect the product's performance and place the safe operation of your process at risk. Look alike substitutions may result in fire, electrical hazards, or improper operation.
- Ensure that all equipment doors are closed and protective covers are in place, except when maintenance is being performed by qualified persons, to prevent electrical shock and personal injury.

WARNING **ELECTRICAL SHOCK HAZARD**

Making cable connections to and servicing this instrument require access to shock hazard level voltages which can cause death or serious injury.

Relay contacts made to separate power sources must be disconnected before servicing.

Electrical installation must be in accordance with the National Electrical Code (ANSI/NFPA-70) and/or any other applicable national or local codes.

Unused cable conduit entries must be securely sealed by non-flammable closures to provide enclosure integrity in compliance with personal safety and environmental protection requirements.

For safety and proper performance this instrument must be connected to a properly grounded three-wire power source.

Proper relay use and configuration is the responsibility of the user.

Do not operate this instrument without front cover secured. Refer installation, operation and servicing to qualified personnel.

SS-MA54
Feb. 1992

Rosemount Analytical Inc.
Uniloc Division
2400 Barranca Parkway
Irvine, CA 92606 USA
Tel: (714) 863-1181

ROSEMOUNT[®] ANALYTICAL
FISHER-ROSEMOUNT™ Managing The Process Better.™

MODEL 1054A pH MICROPROCESSOR ANALYZER

TABLE OF CONTENTS

Section	Title	Page
1.0	DESCRIPTION AND SPECIFICATIONS	1
1.1	Features and Applications.....	1
1.2	Physical Specifications-General.....	2
1.3	Instrument Specifications	2
1.4	Recommend Sensors	2
2.0	INSTALLATION	3
2.1	General.....	3
2.2	Unpacking and Inspection	3
2.3	Mechanical Installation	3
2.3.1	Panel Mounting.....	3
2.3.2	Wall Mounting.....	3
2.3.3	Pipe Mounting.....	3
2.3.4	Wall Mounting Enclosure	3
2.4	Electrical Wiring.....	4
2.4.1	Power Input Wiring	4
2.4.2	Output Wiring.....	4
3.0	DESCRIPTION OF CONTROLS	15
3.1	Keyboard Functions	15
4.0	CONFIGURATION	19
4.1	Configuration	19
4.2	Alarm 1 and 2	22
4.3	Interval Timer	24
4.4	Temperature	26
4.5	Current Output	28
4.6	pH Electrode Diagnostics.....	30
4.7	Solution Temperature Compensation and Isopotential Point.....	32
4.8	Defaults.....	34
4.9	Automatic Buffer Mode.....	36
4.10	Alarm Setpoint	38
4.11	Output Scale Expansion.....	39
4.12	Simulate Current Output	40
5.0	START- UP AND CALIBRATION.....	41
5.1	Start- Up and Calibration.....	41
5.2	Temperature Calibration	41
5.3	Buffer Calibration.....	41
5.4	pH Standardization.....	42
5.5	pH Glass Slope.....	42
5.6	Sensor Maintenance.....	42
6.0	KEYBOARD SECURITY	43
6.1	Keyboard Security	43
7.0	THEORY OF OPERATION.....	44
7.1	Theory of Operation.....	44

TABLE OF CONTENTS CONT'D.

Section	Title	Page
8.0	DIAGNOSTICS AND TROUBLESHOOTING.....	45
8.1	Diagnostics.....	45
8.1.1	Fault Mnemonics	45
8.1.2	Temperature Compensation	45
8.2	Troubleshooting	46
8.2.1	Installation Failure.....	46
8.2.2	LCD/LED Display Test	46
8.2.3	Software Version	46
8.2.4	Sensor Troubleshooting.....	46
8.2.5	Electrode Input	46
8.2.6	CPU Board Replacement	46
8.2.7	Power Board Replacement.....	46
9.0	RETURN OF MATERIALS	49
9.1	General.....	49
9.2	Warranty Repair.....	49
9.3	Non Warranty Repair	49

LIST OF FIGURES

Figure No.	Title	Page
2-1	Panel Mounting Cutout	5
2-2	Panel Mounting Tab Installation.....	6
2-3	Wall Mounting J-Box Installation.....	7
2-4	Wall Mounting J-Box Wiring.....	8
2-5	Pipe Mounting Installation	9
2-6	Wall Mount Enclosure Dimensions and Mounting	10
2-7	Electrical Wiring.....	11
2-8	Integral Preamp Wiring for Group I Panel Mount Enclosure	12
2-9	Integral Preamp Wiring for Group II Panel Mount Enclosure	13
3-1	Keyboard Overlay.....	16
4-1	Menu Items	20
4-2	Alarms 1 and 2 Configuration.....	23
4-3A	Interval Timer Example.....	24
4-3	Interval Timer Configuration	25
4-4	Temperature Configuration	27
4-5	Current Output Configuration	29
4-6	pH Electrode Diagnostics Configuration.....	31
4-7	Solution Temperature Compensation & Isopotential Point Configuration	33
4-8	Default State Configuration	35
4-9	Automatic Buffer Mode Configuration	37
4-10	Alarm Setpoint.....	38
4-11	Output Scale Expansion.....	39
4-12	Simulate Current Output.....	40

LIST OF TABLES

Table No.	Title	Page
3-1	Key Description	17
3-2	Information Mnemonics	18
3-3	Set Function Mnemonics	18
4-1	Configuration Work Sheet.....	21
4-2	Relay States For Various Analyzer Conditions & Alarm/Default Config.	34
8-1	Fault Mnemonics	45
8-2	RTD Resistance Values	45
8-3	Troubleshooting Guide	47
8-4	Sensor Input to Analyzer vs. pH at Four Temperatures.....	46
8-5	Replacement Parts and Accessories	48
8-6	Ordering Information	48

SECTION 1.0

DESCRIPTION AND SPECIFICATIONS

- *FM AND CSA APPROVED For Class I, Division 2, Gas Groups A, B, C, and D.*
- *pH ELECTRODE DIAGNOSTICS warn user of the need for calibration or electrode replacement.*
- *AUTOMATIC BUFFER RECOGNITION with stored buffer-temperature curves.*
- *NEMA 4X (IP65) WEATHERPROOF CORROSION-RESISTANT ENCLOSURE.*
- *NO BATTERY BACK-UP REQUIRED. Non-volatile EEPROM memory.*
- *SPECIFIC PROCESS TEMPERATURE COMPENSATION for pH changes due to temperature.*

1.1 FEATURES AND APPLICATIONS

The Model 1054A Microprocessor Analyzers, with the appropriate sensor, are designed to continuously measure and control pH, ORP, conductivity, percent concentration, dissolved oxygen and total free chlorine in industrial and municipal processes.

The Model 1054A is housed in a NEMA 4X (IP65) weatherproof corrosion-resistant, flame retardant enclosure suitable for panel, pipe or wall mounting. All functions are accessed through the front panel membrane keyboard which features tactile feedback. Measurement data may be read at any time; however, settings may be protected against accidental or unauthorized changes by a user selectable security code. The display indicates the measured value in engineering units as well as temperature, alarm status, hold output and fault conditions.

The analyzer transmits an isolated current output which is continuously expandable over the measurement range for either direct or reverse action. A hold output function is available for allowing manual control during routine sensor maintenance. During hold mode the output will be at a preset or last process value.

In the event of one of the following conditions, the analyzer will drive the output to a preset value in addition to displaying a fault code. Continuous self diagnostics alert the user to the following:

- Broken or cracked electrode
- Worn out or non-immersed electrode
- Calibration or coated electrode warning
- Faulty slope value (off-line only)
- Open wiring
- Analyzer electronics failure
- Faulty temperature element or temperature value

With automatic buffer recognition, the analyzer recognizes the buffers, then calculates the electrode slope using stored pH-temperature curves for ten common buffers.

Dual alarms are a standard feature on the Model 1054A and are programmable for either high or low operation. Alarm 2 may be programmed to activate in event of a failure detected by the continuous diagnostics. Both alarms feature independent setpoints, adjustable hysteresis and time delay action. A dedicated interval timer with relay is also provided for chemical or ultrasonic cleaning.

The 1054A automatically compensates the pH reading for process temperature changes. Automatic or manual temperature compensation is keyboard selectable. The process temperature can be read on the display in °F or °C. Additional process temperature compensation is available.

The Analyzer includes a 0.7 inch digital display available in LCD or LED format.

An optional wall mount enclosure is available for use in high solids or very cold environments.

1.2 PHYSICAL SPECIFICATIONS - GENERAL

Panel Mount Enclosure: Black, ABS, NEMA 4X, IP65,
CSA Enclosure 4.
144 X 144 X 192mm, DIN size.
(5.7 X 5.7 X 7.6 inches).

Wall Mount Enclosure: Weatherproof, Heavy duty fiberglass
reinforced thermoplastic.
300 X 330 X 190mm
(11.75 X 13 X 7.5 inches).

Front Panel: Membrane keyboard with tactile feedback and user
selectable security. Black and white on grey.

Digital Display: LCD, black on grey
Optional, red LED
Character Height: 18mm (0.7 inch)

Electrical Classification:

Group I Panel Mount Enclosure:

FM	Class I, Div. 2, Group A thru D. 28 Vdc relays - 6.0 amps resistive only 150 mA - Groups A & B; 400 mA - Group C; 540 mA - Group D; Ci = 0; Li = 0
CSA	Class I, Div. 2, Group A thru D. 28 Vdc, 110 Vac & 230 Vac relays 6.0 Amps resistive only

Group II Wall Mount Enclosure: General Purpose

Power: 115 Vac, $\pm 10\%$, 50/60 Hz $\pm 6\%$, 4.0 W
230 Vac, $\pm 10\%$, 50/60 Hz $\pm 6\%$, 4.0 W

Current Output: Isolated, 0-20 mA or 4-20 mA
into 600 ohms maximum load, Direct or Reverse
Output Dampening: 0-255 seconds.

Ambient Temperature: -10 to 65°C (14 to 149°F)

Ambient Humidity: LCD: 0-85% RH
LED: 0-95% RH

Alarms: Dual, field selectable High/Low, High/High, Low/Low
Alarm 2 configurable as a fault alarm
Time Delay 0 to 255 seconds
Dual Setpoints, continuously adjustable
Hysteresis is adjustable up to 2 pH units
for low side/High Alarm and high side/Low Alarm

Interval Timer: Interval: Minimum 10 minutes
On Counts: 1 to 60
On Duration: 1 to 299 seconds
Off Duration: 1 to 299 seconds
Wait Duration: 1 to 299 seconds
Controls dedicated relay

Relay Contacts: Epoxy Sealed Form A contacts, SPST, Normally
Open.

	Resistive	Inductive
28 Vdc	6.0 Amps	3.0 Amps
115 Vac	6.0 Amps	3.0 Amps
230 Vac	6.0 Amps	1.5 Amps

Weight/Shipping Weight: 1.1 kg/1.6 kg (2.5 lbs./3.5 lbs.)

The **Model 1054A pH Analyzer** requires a preamplifier to convert the high impedance pH glass electrode signal to a low impedance signal. The preamplifier may be located in one of three areas; in the pH sensor for best performance, in a remote junction box when process temperatures exceed 80°C (176°F) in submersion applications, or in the analyzer when the distance between the pH sensor and the analyzer is 4.5 meters (15 feet) or less. The result is that the pH signal may then be reliably transmitted from the sensor to the analyzer using standard shielded 4-wire instrument cable.

The Model 1054A pH measures over the full range of 0-14 pH. The current output may be calibrated to represent any 1 to 14 pH span. A two-point calibration is made by immersing the sensor in two different buffer solutions and entering the pH values. When two buffers are used, the microprocessor automatically calculates the electrode slope which is used for self-diagnostics. This electrode slope can be read on the display and manually adjusted for longer electrode life. A one-point process standardization is easily accomplished by entering the pH value of a grab sample.

1.3 INSTRUMENT SPECIFICATIONS @ 25°C

Measurement Range: 0 to 14 pH
Output Scale Expansion: Zero suppression: up to 13 pH units
Span: Any pH from 1 to 14

Accuracy: ± 0.01 pH
Repeatability: ± 0.01 pH
Stability: ± 0.01 pH/month, non-cumulative
Temperature Coefficient: Input: ± 0.003 pH/°C
Output: ± 0.006 pH/°C
Temperature Compensation: PT 100 RTD, Automatic or Manual
-15 to 100°C (5 to 212°F)

1.4 RECOMMENDED SENSORS:

Model 300 Retractable pH Sensor
Model 320B Flow Through pH Sensor
Model 320HP High Purity pH Sensor *
Model 328A Steam Sterilizable pH Sensor
Model 381 Insertion/Submersion/Flow pH Sensor
Model 385 Retractable pH Sensor
Model 399 Disposable pH Sensor
Model 389 Disposable pH Sensor

* Model 1054pH includes programmable temperature corrections required for the presence of ammonia used in treating high purity water

SECTION 2.0 INSTALLATION

2.1 GENERAL. This analyzer's enclosure is suitable for outdoor use. However it should be located in an area where temperature extremes, vibrations, electromagnetic and radio frequency interferences are minimized or absent.

2.2 UNPACKING AND INSPECTION. Inspect the analyzer for shipping damage. If damaged, notify the carrier immediately. Confirm that all items shown on the packing list are present. Notify Rosemount Analytical if items are missing.

2.3 MECHANICAL INSTALLATION. Select an installation site that is at least one foot from any high voltage conduit, has easy access for operating personnel, and is not in direct sunlight. Mount the Model 1054A pH as follows:

1. Remove the four screws that secure the rear cover of the enclosure (not required for wall mounting, options 20 or 21). The latching hardware for panel and pipe mounting is located inside the rear cover.
2. For standard panel and pipe mounting, remove the four screws holding the front panel assembly of the enclosure and carefully pull the front panel and connected printed circuit boards straight out (not required for options 20 or 21).
3. Follow the procedure for the appropriate mounting configuration: Section 2.3.1 for panel mounting, Section 2.3.2 for wall mounting, or Section 2.3.3 for pipe mounting, or Section 2.3.4 for wall mounting enclosure.

2.3.1 Panel Mounting (Standard). The Model 1054A pH is designed to fit into a DIN standard 137.9 mm X 137.9 mm (5.43 inch X 5.43 inch) panel cutout (refer to Figures 2-1 and 2-2).

1. Prepare the analyzer as described in Section 2.3.
2. Install the mounting latches as shown in Figure 2-2 (latches are shown oversize for clarity). If the latches are not installed exactly as shown, they will not work correctly. The screws provided are self-tapping. Tap the screw the full depth of the mounting latch (refer to side view) leaving a gap greater than the thickness of the cutout panel.

3. Align the latches as shown and insert the analyzer enclosure through the front of the panel cutout. Tighten the screws for a firm fit. To avoid damaging the mounting latches, do not use excessive force.
4. Replace the front panel assembly. Circuit boards must align with the slots on the inside of the enclosure. Replace the door and four front panel screws.

2.3.2 Wall Mounting (Option-07). Refer to Figures 2-3 and 2-4. The integral preamp (1054A Code 54) should not be used with this option.

1. Prepare the analyzer as described in Section 2.3.
2. Mount the junction box and bracket to the analyzer with the hardware provided. All wiring can be brought to the terminal strip prior to mounting the analyzer.
3. Place the metal stiffener on the inside of the analyzer and mount the two ¼-inch conduit fittings using two each weather seals as shown. Mount NEMA 4X conduit plug (included) into center conduit hole.
4. Mount the analyzer to the junction box using the ¼-inch conduit fittings.
5. Complete wiring from the 1054A pH to the junction box (Figure 2-4).

2.3.3 Pipe Mounting (Option-08). The 2" pipe mounting bracket includes a metal plate with a cutout for the 1054A pH refer to Section 2.3 for mounting the analyzer into the plate. Mounting details are shown in Figure 2-5.

2.3.4 Wall Mounting Enclosure (Options-20, 21). Refer to Figure 2-6. In this configuration the analyzer is housed in NEMA 4X heavy duty enclosure and may be mounted on a wall or handrail. Sufficient clearance should be provided in front of the enclosure to permit opening the door, which is hinged on the left side.

2.4 ELECTRICAL WIRING. The Model 1054A pH has three conduit openings in the bottom rear of the analyzer housing which will accommodate 1/4-inch conduit fittings. From a back view, the conduit opening on the left is for timer, alarm, and AC connections; the center is for signal output and the opening on the right is for sensor wiring.

The wall mount enclosure has three 3/4-inch conduit openings, two with 3/4-inch fittings and one with a NEMA 4X conduit plug. From the front view the conduit opening on the left is for sensor wiring; the center is for signal output, and the right is for timer, alarm and AC power supply connections. Sensor wiring should always be run in a separate conduit from power wiring.

NOTE

Option-07 wall mount: use opening on the left for sensor wiring. (Refer to Figure 2-4 for wiring.)

NOTE

Option-54 requires installation of the integral preamplifier module. (Refer to Figure 2-8 for installation and wiring.)

2.4.1 Power Input Wiring. The Model 1054A pH has been configured at the factory for either 115 VAC or 230 VAC power. Operating power can be changed by a selector switch located on the power supply board (P/N 23056-02/03). To access this switch, remove the four screws from the front keyboard and pull the electronic assembly straight out.

Connect AC power to TB1-7 and -8, ground to the TB3-8 (refer to Figure 2-7).

CAUTION

The sensitivity and stability of the analyzer will be impaired if the input wiring is not grounded. DO NOT apply power to the analyzer until all electrical connections are verified and secure. The following precautions are a guide using UL 508 as a safeguard for personnel and property.

1. AC connections and grounding must be in compliance with UL 508 and/or local electrical codes.
2. The metal stiffener is required to provide support and proper electrical continuity between conduit fittings.
3. This type 4/4X enclosure requires a conduit hub or equivalent that provides watertight connect, REF UL 508-26.10.
4. Watertight fittings/hubs that comply with the requirements of UL 514B are to be used.
5. Conduit hubs are to be connected to the conduit before the hub is connected to the enclosure, REF UL 508-26.10.
6. If the metal support plate is not used, plastic fittings must be used to prevent structural damage to the enclosure. Also, appropriate grounding lug and awg conductor must be used with the plastic fittings.

2.4.2 Output Wiring. The signal output and alarm connections are made to terminals 1 through 6 of TB1 and terminals 1 and 2 of TB3 (refer to Figure 2-7).

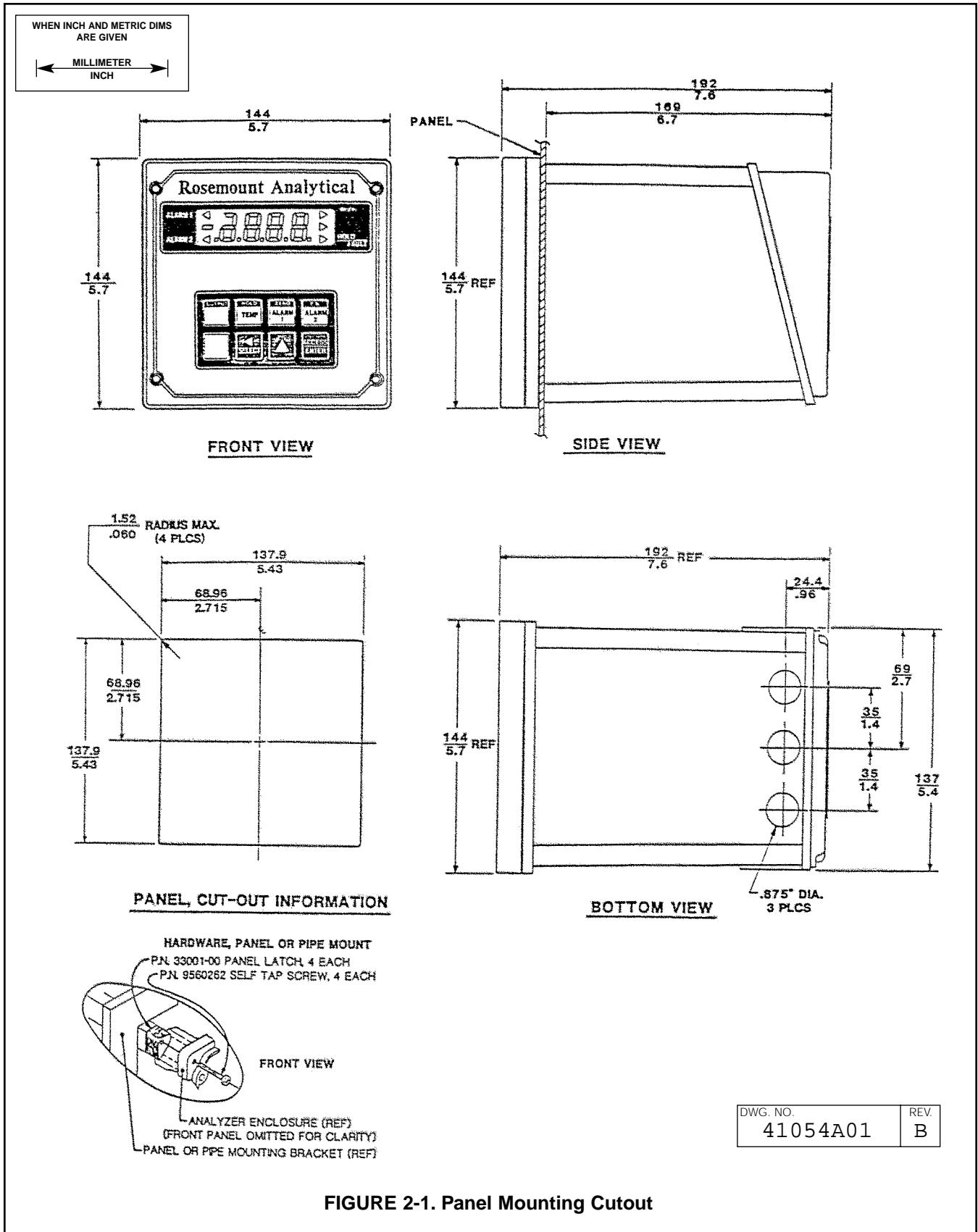
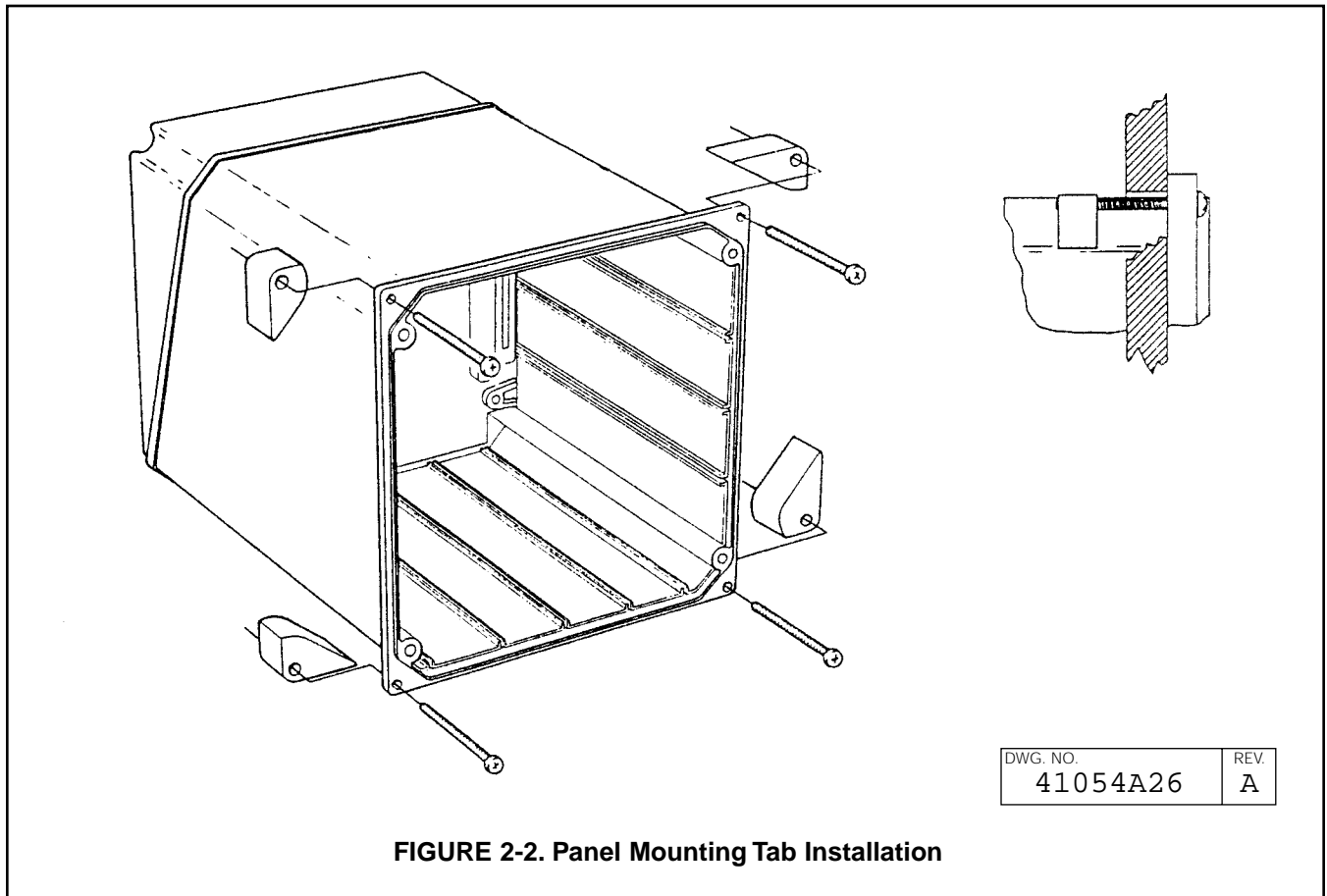
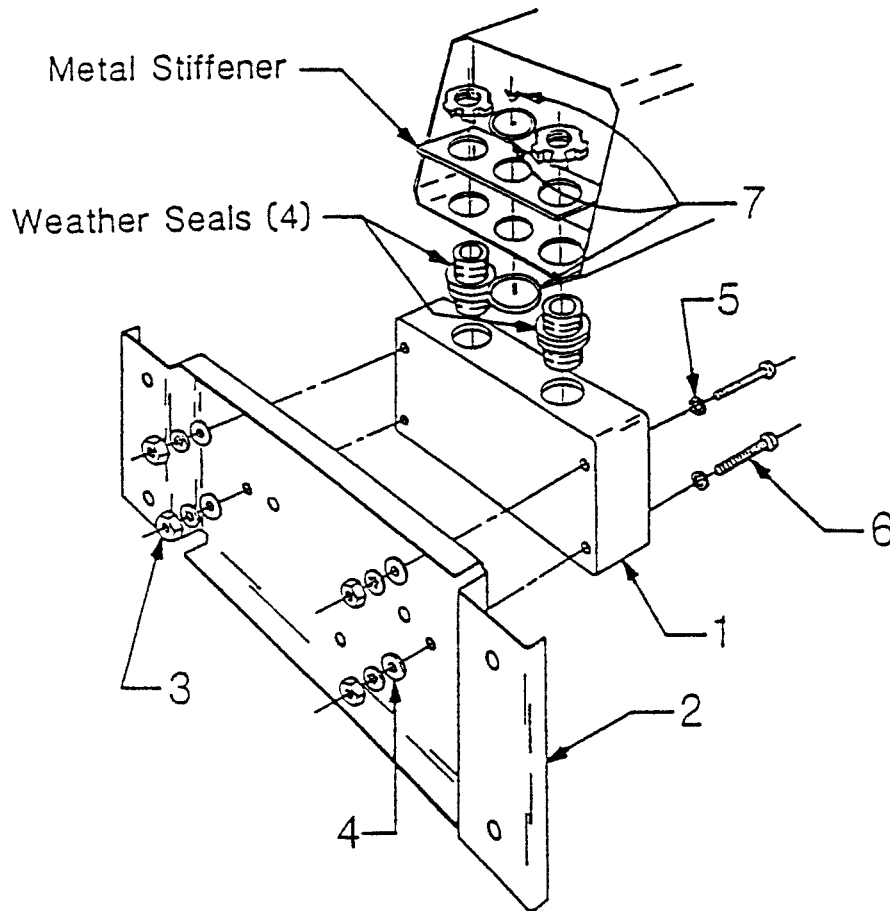

FIGURE 2-1. Panel Mounting Cutout





<u>ITEM</u>	<u>PART NUMBER</u>	<u>DESCRIPTION</u>	<u>QUANTITY</u>
1	23058-01	S Assy, J-Box	1
2	33030-00	Bracket, wall mtg	1
3	9900600	Nut, 6-32 Hex	4
4	9910600	Washer, Flat #6	4
5	9910610	Washer, Lock Int. #6	8
6	9600612	Screw, 6-32 X .75	4
7	9510048	Seal, Weathertight	1

DWG. NO. 41054A27	REV. A
----------------------	-----------

FIGURE 2-3. Wall Mounting J-Box Installation

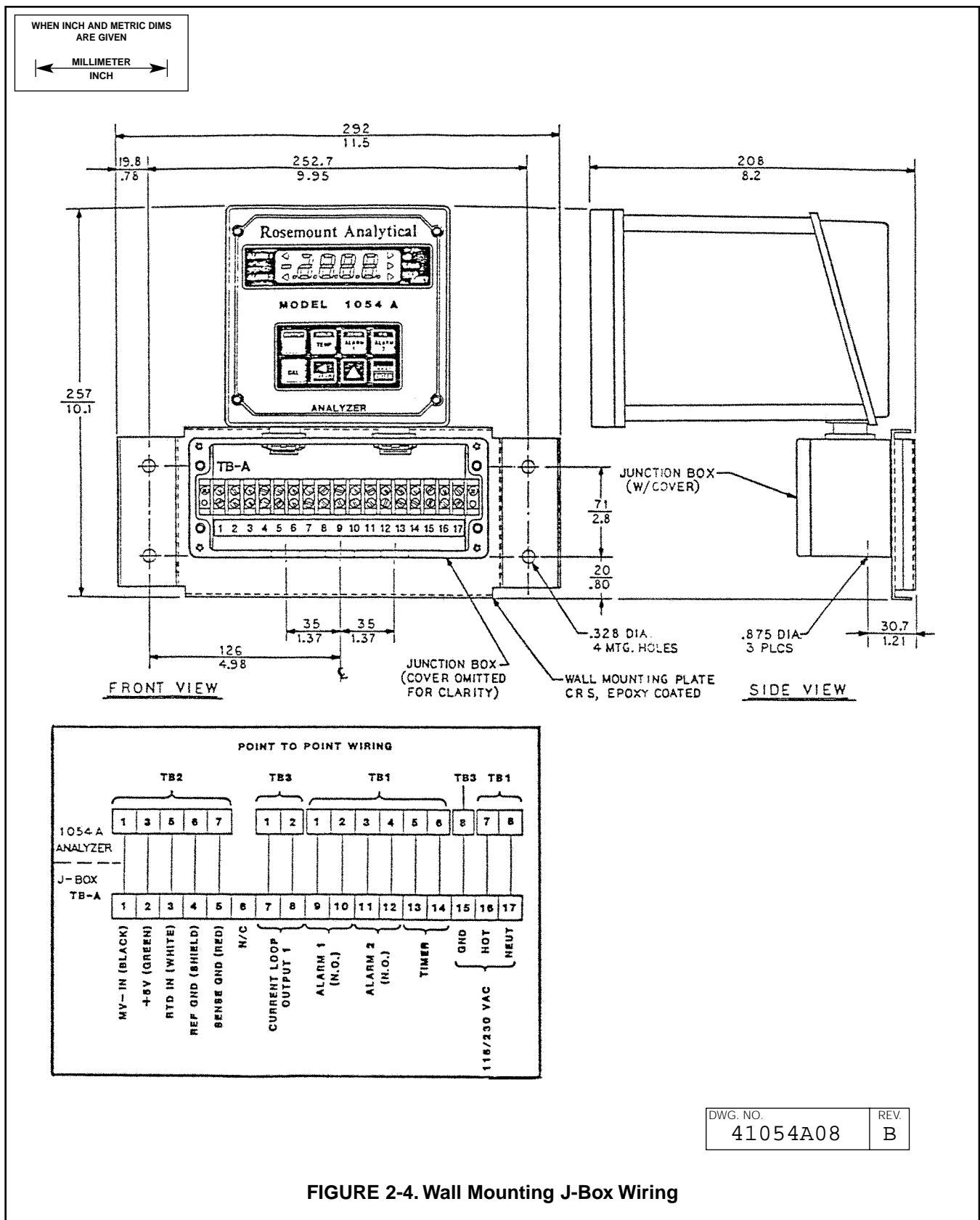

FIGURE 2-4. Wall Mounting J-Box Wiring

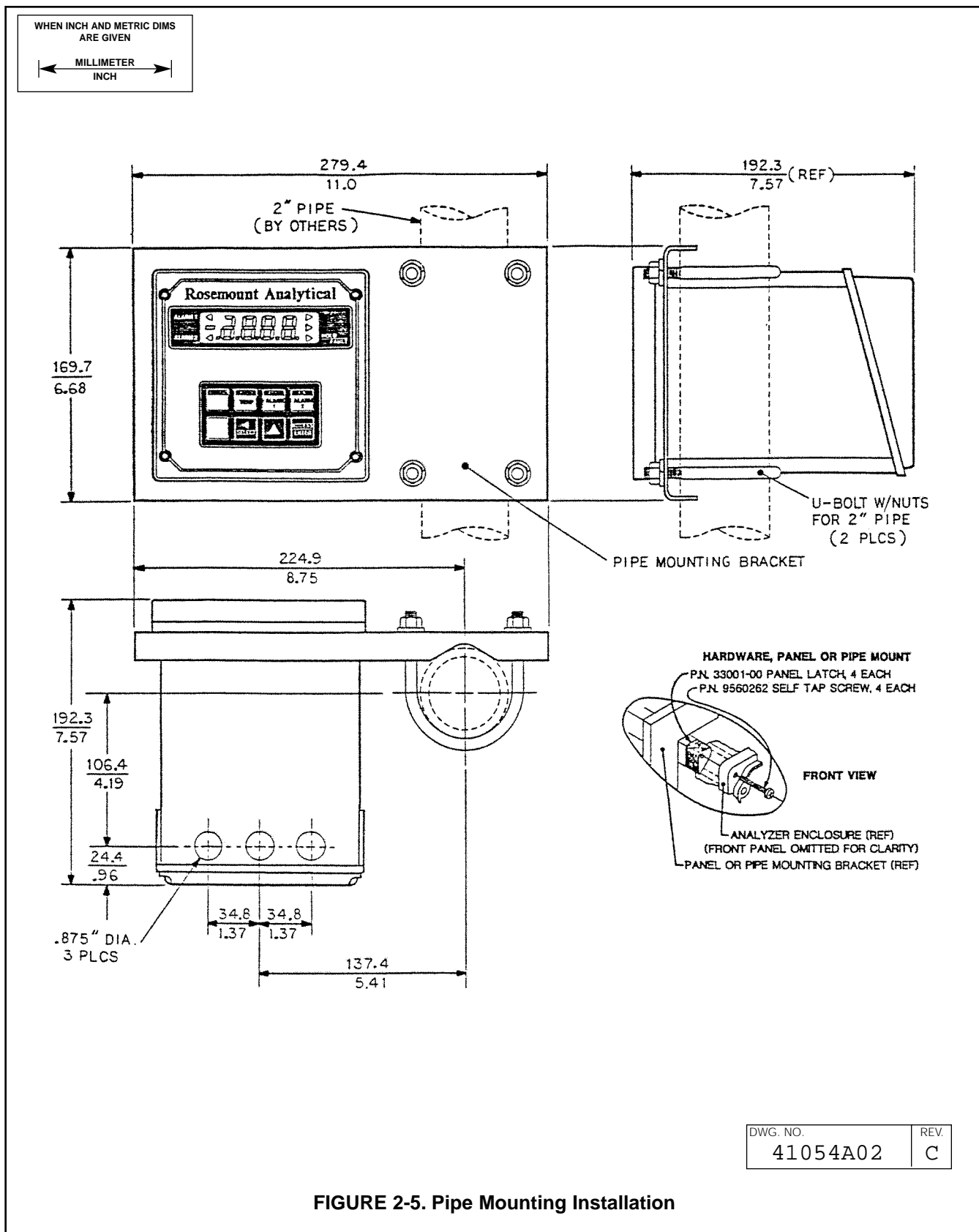

FIGURE 2-5. Pipe Mounting Installation

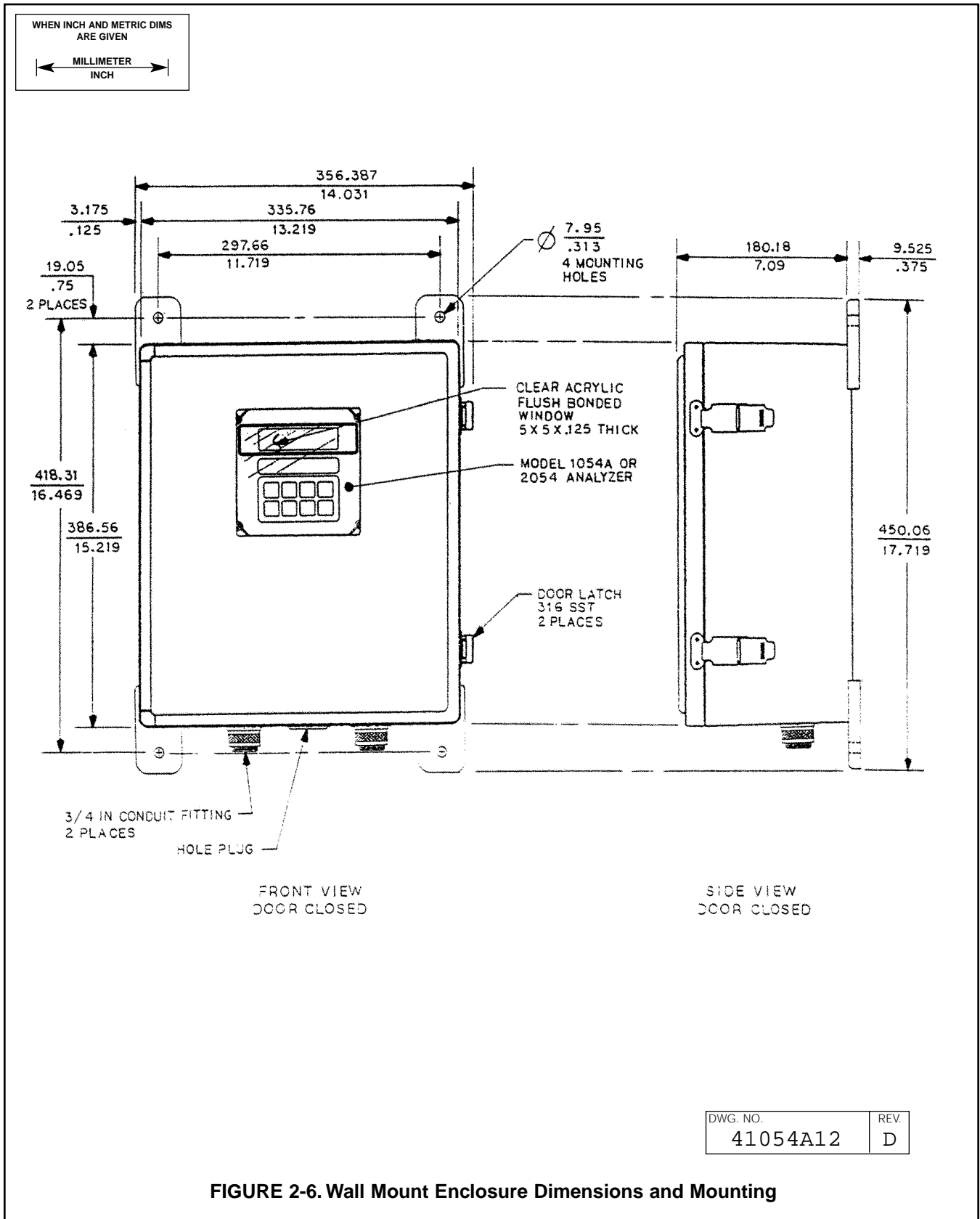
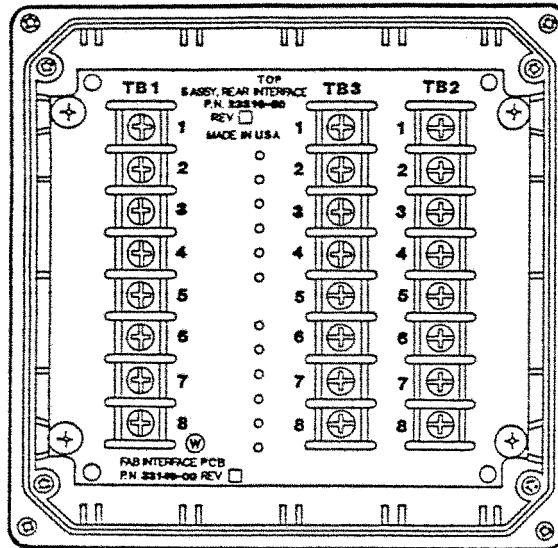
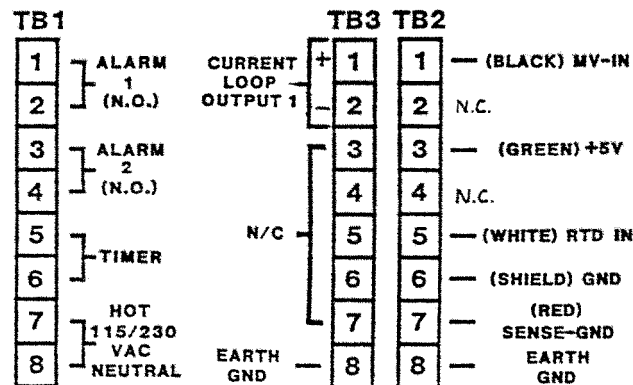

FIGURE 2-6. Wall Mount Enclosure Dimensions and Mounting



BACK VIEW / COVER OMITTED

FIELD TERMINAL BOARD CONNECTIONS



DWG. NO. 41054A03	REV. A
----------------------	-----------

FIGURE 2-7. Electrical Wiring

BACK VIEW / COVER OMITTED

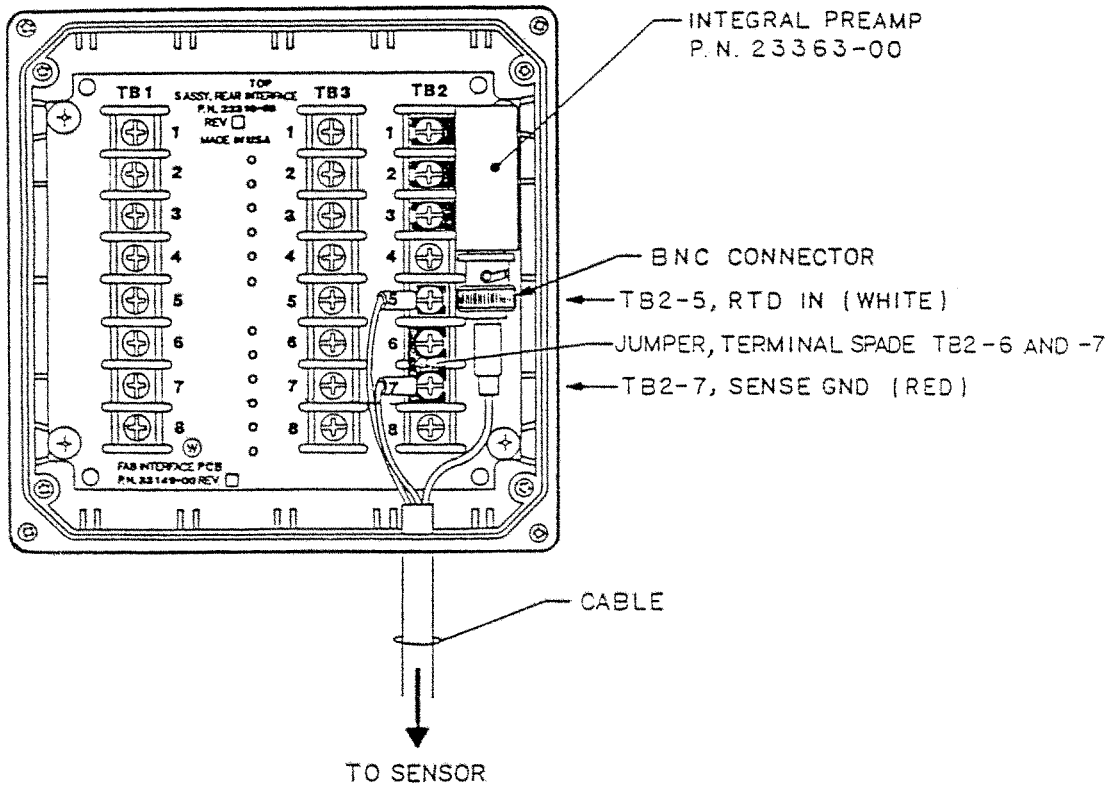

DWG. NO.	REV.
41054A04	B

FIGURE 2-8. Integral Preamp Wiring for Group I Panel Mount Enclosure

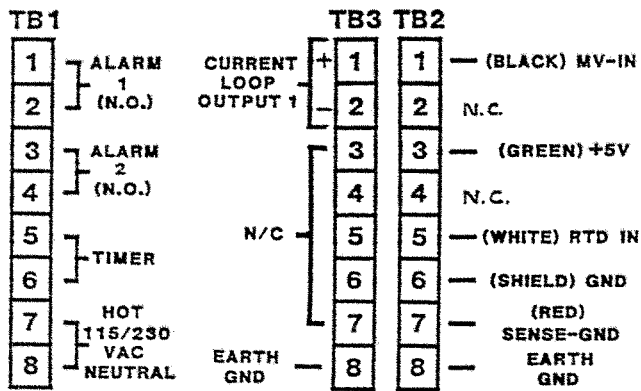
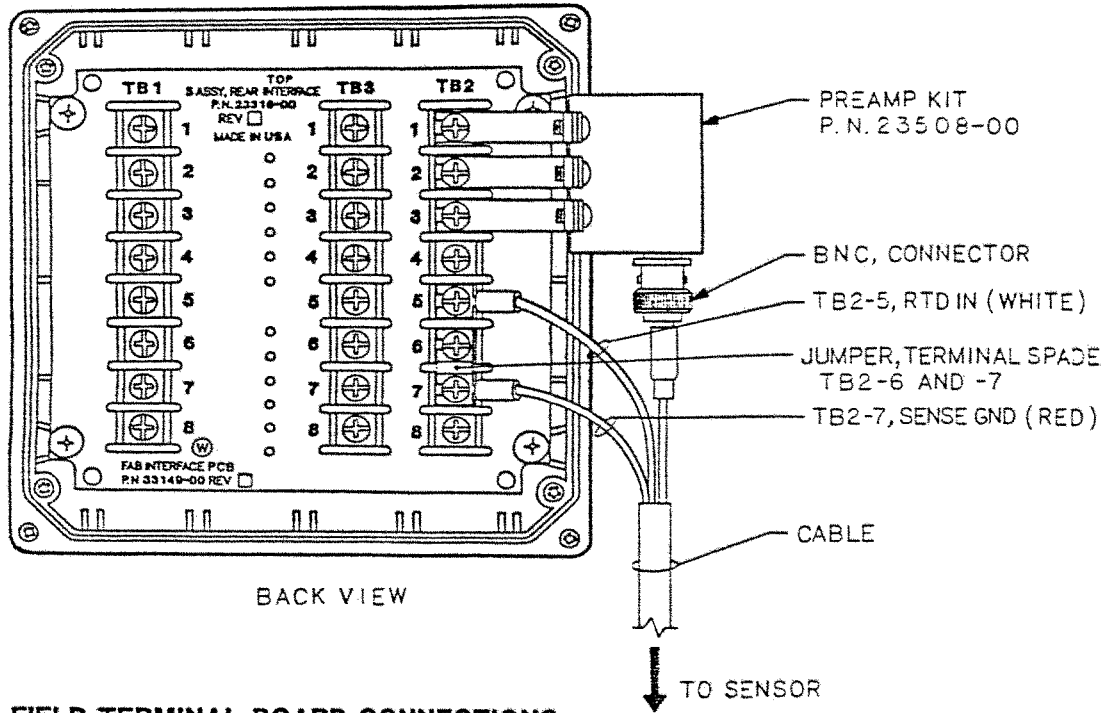

DWG. NO.	REV.
41054A14	A

FIGURE 2-9. Integral Preamp Wiring for Group II Wall Mount Enclosure

SECTION 3.0 DESCRIPTION OF CONTROLS

3.1 KEYBOARD FUNCTIONS. All functions of the 1054A pH are accessed through keyboard entry routines. The analyzer uses no switches or potentiometers.

The four keys across the top row and the **CAL** and **ENTER** keys are dual function. One press of the key will display the value of the function shown on the lower portion of the key. A quick double press of the key will display the value of the function shown on the upper portion of the key. Each of these keys have read functions that can be accessed without security code entry. Each key also has a calibration or set function when used with the **SELECT** key. This function requires entry of the security code when the security feature is active. (Refer to Section 6.0 for keyboard security.)

NOTE

When no key is pressed for a period of 60 seconds the analyzer will default to reading pH.

CAUTION

The **HOLD** function and the **CAL** function are not read functions. Refer to section 5.3.

A. Standardize pH. Standardization of the pH sensor is achieved by pressing the **pH** key once, followed immediately by pressing the **SELECT** key. "5tđ" displays to acknowledge the standardize function, followed by the Numeric Display for user input. Entering the known pH of the measured solution will cause the analyzer to restandardize the sensor. The slope value will not be changed. Refer to Section 5.4.

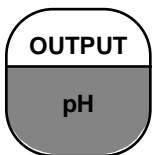

B. Standardize Temperature. Standardization of the temperature is achieved by pressing the **TEMP** key once, followed immediately by pressing the **SELECT** key. "Rđđ" displays to acknowledge the standardization function, followed by the Numeric Display for user input. Entering the known temperature of the measured solution will cause the analyzer to restandardize the temperature reading. Refer to Section 5.2.

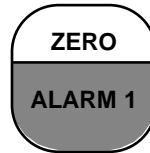
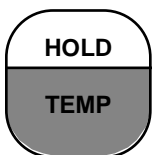

C. Alarm 1 and Alarm 2 Setpoint. The alarm setpoint may be adjusted by pressing the **ALARM 1** or **ALARM 2** key once, followed by pressing the **SELECT** key. "Rđđ" displays, followed by the Numeric Display for user input. Refer to Section 4.10.

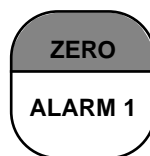

D. Current Output – Zero Setpoint. The zero point (0 or 4 mA) of the pH output range is adjusted by pressing the **ZERO** key twice, followed by pressing the **SELECT** key. "Rđđ" displays, followed by the Numeric Display for user input. Refer to Section 4.11.

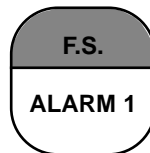

E. Current Output – F.S. Setpoint. The full scale point (20 mA) of the pH output range is adjusted by pressing the **F.S.** key twice, followed by pressing the **SELECT** key. "Rđđ" displays, followed by the Numeric Display for user input. The full scale setpoint for the other output. Refer to Section 4.11.

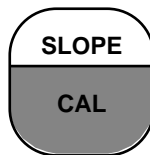

F. Two Buffer Calibration. A two buffer calibration is initiated by pressing the **CAL** key once. Refer to Section 5.3.

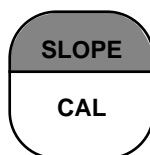

G. pH Glass Slope. The millivolt output per pH unit is adjusted by pressing the **SLOPE** key twice, followed by pressing the **SELECT** key once. "Rđđ" displays, followed by the Numeric Display for user input. Refer to Section 5.5.

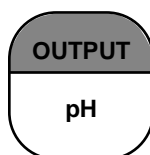

H. Simulate Current Output. The pH output can be simulated by pressing the **OUTPUT** key twice, followed by pressing the **SELECT** key. The Numeric Display appears for user input. Refer to Section 4.12.

3.1.1 Item Selection and Value Adjustment Keys.

The three keys located on the lower right side of the keypad are used for menu navigation, value adjustment and entry, and item selection. These keys perform the following functions:



A. SELECT/Shift (◀) Key. This key is used to select the displayed menu, or for shifting to the next digit in the Numeric Display.

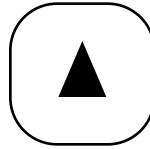

Numeric display.

B. Scroll Key (▲). This key is used to scroll through menu when selected, or scroll through digits on the active (flashing) Numeric Display. Holding key down auto scrolls through the main menu and

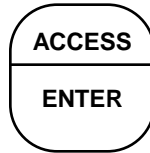

C. ACCESS/ENTER Key. This key is used to **ACCESS** the Set Mode (Section 4.1.2) and to **ENTER** the displayed value into memory (from Numeric Display).

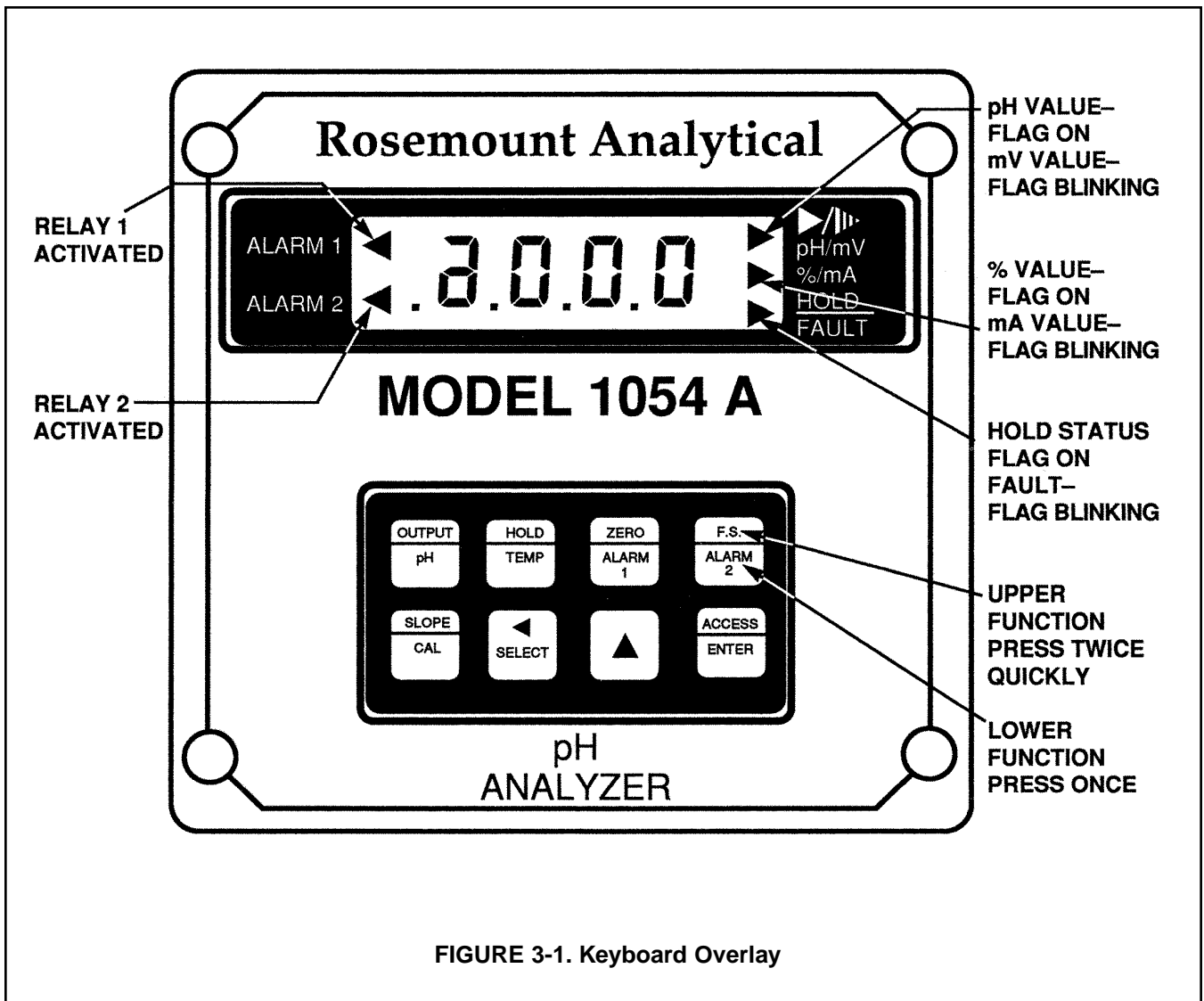

FIGURE 3-1. Keyboard Overlay

TABLE 3-1. Key Description



	MAIN FUNCTION (PRESS ONCE)	SECOND FUNCTION (PRESS TWICE QUICKLY)
	<p>Displays - pH.</p> <p>Set Function (w/SELECT) - One point standardization of pH.</p>	<p>Displays - current output (mA or % full scale).</p> <p>Set Function (w/SELECT) - Simulates current output.</p>
	<p>Displays - process temperature (°C or °F).</p> <p>Set Function (w/SELECT) - One point standardization of temperature.</p>	<p>Initiates or removes analyzer from hold condition.</p>
	<p>Displays - Alarm 1 setpoint.</p> <p>Set Function (w/SELECT) - Sets Alarm 1 setpoint.</p>	<p>Displays - low current setpoint (0 or 4 mA value).</p> <p>Set Function (w/SELECT) - Sets low current point (0 or 4 mA value).</p>
	<p>Displays - Alarm 2 setpoint.</p> <p>Set Function (w/SELECT) - Sets Alarm 1 setpoint.</p>	<p>Displays - full scale output setpoint.</p> <p>Set Function (w/SELECT) - Sets full scale output point.</p>
	<p>Two Point Calibration.</p>	<p>Displays - electrode slope (efficiency).</p> <p>Set Function (w/SELECT) - manually sets electrode slope (efficiency).</p>
		
<p>Select sub menu (mnemonic display). Shift to next digit (numeric display).</p>		
		
<p>Scroll through menu (mnemonic display). Scroll digits (numeric display). Holding key down autoscrolls digits or set menu items.</p>		
		
<p>Press twice to access set-up menu. Enter displayed value into memory. Enter displayed menu item (flashing) into memory.</p>		

TABLE 3-2. Information Mnemonics

MNEMONIC	DESCRIPTION	MNEMONIC	DESCRIPTION
Ab1	Automatic Buffer 1	L0C	Access locked - enter security code
Ab2	Automatic Buffer 2	PcE	Displays pH output in percent
Adj	Adjustment to value reading	PH	pH Display
bAd	Incorrect entry	SEt	Set mode
bF1	Buffer 1	S.P	Simulates pH output (percent)
bF2	Buffer 2	SC1	Simulates pH output (mA)
doc	Displays pH output value in mA	SLP	Displays pH electrode slope
HLd	Analyzer in hold mode	SP1	Displays alarm 1 setpoint
Hi	Displays 20 mA setpoint (pH)	SP2	Displays alarm 2 setpoint
iTr	Interval timer activated	Std	Standardize pH
L0	Displays 0 or 4 mA setpoint (pH)		

TABLE 3-3. Set Function Mnemonics

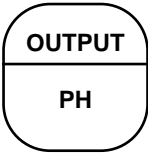
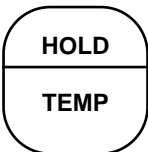
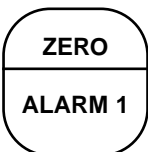
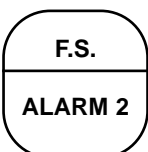
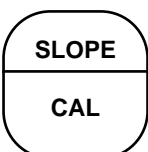
AbF	Auto buffer mode	dur	Timer duration	OUt	Config. output 1 (pH)
AL1	Alarm 1 setup	Ei n	Display mV input	PcE	Display output in percent
AL2	Alarm 2 setup	dF	Temperature °F	rL1	Relay 1 fault setup
Atc	Automatic temp. comp.	FLt	Use alarm as fault alarm	rL2	Relay 2 fault setup
dC	Temperature °C	Hi	Relay action - high	rES	Impedance value
CAL	Calibration impedance setpoint	H-L	Alarm logic	rPH	Normal process pH
C0d	Security Code	hr	Hours	SEC	Seconds
cnt	Timer count	HYS	Hysteresis	SHt	Cracked glass impedance limit
CUr	Config. current output	i nE	Interval period	SHD	Show fault history
Cur	Config. fault output 1	i nE	Timer setup	E-C	Temperature config.
cUr	Default current setpoint	i PH	Isopotential pH	EC0	Temperature coefficient
dAY	Days	i S0	Isopotential point	Ei L	Timer - time remaining
dFE	Fault Configuration	L0	Relay action - low	E0n	Timer status
d-0	Display output	no n	No action on fault	UEr	User version
d-t	Display temperature	OFF	Alarm not used	u n	Minutes
doc	Display output in mA	o nE	Timer on time	420	4mA to 20mA output
doF	Relay delay off time	oFF	Relay open on fault	020	0mA to 20mA output
don	Relay delay on time	0n	Use alarm as process alarm		
dPn	Dampen output	OFFt	Timer off time		
dES	LCD/LED Display test	0i d	Old electrode impedance limit		

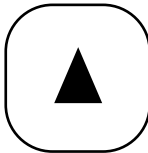
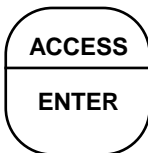
SECTION 4.0 CONFIGURATION

4.1 CONFIGURATION. This section details all of the items available in the Set Mode to configure the analyzer to a specific application.

4.1.1 Configuration Work Sheet. The configuration work sheet on page 21 should be filled out before proceeding with the analyzer's configuration. This sheet gives a brief parameter description, the factory setting, and a space for user setting.

4.1.2 Set Mode. Display mnemonic 5EE . Most of the analyzer's configuration is done while in the Set Mode. Please refer to Figure 4-1 for the layout of all menu items. All menu variables are written to the analyzer's EEPROM (memory) when selected and remain there until changed. As these variables remain in memory even after the analyzer's power is removed, the Model 1054A pH configuration may be performed prior to installing it.

1. Power up the analyzer. Only power input wiring is required for analyzer configuration. (Refer to Section 2.4.1.) The analyzer's display will begin showing values and/or fault mnemonics. All fault mnemonics will be suppressed while the analyzer is in Set Mode (the fault flag will continue to blink).

2. Enter Set Mode. Pressing the **ACCESS** key twice in rapid succession will place the analyzer in Set Mode. The display will show "5EE" to confirm that it is in Set Mode. It will then display the first item in the Set Menu "E1 n". The analyzer is now ready for user configuration.

NOTE

If "L00" displays, the Keyboard Security Code must be entered to access the Set Mode. (Refer to Section 6.0.)

3. (Refer to the configuration work sheet on page 21.) Analyzer variables can be entered in any order. On initial configuration, however, it is recommended that the variables be entered in the order shown on the work sheet. This will reduce the chance of accidentally omitting a needed variable.

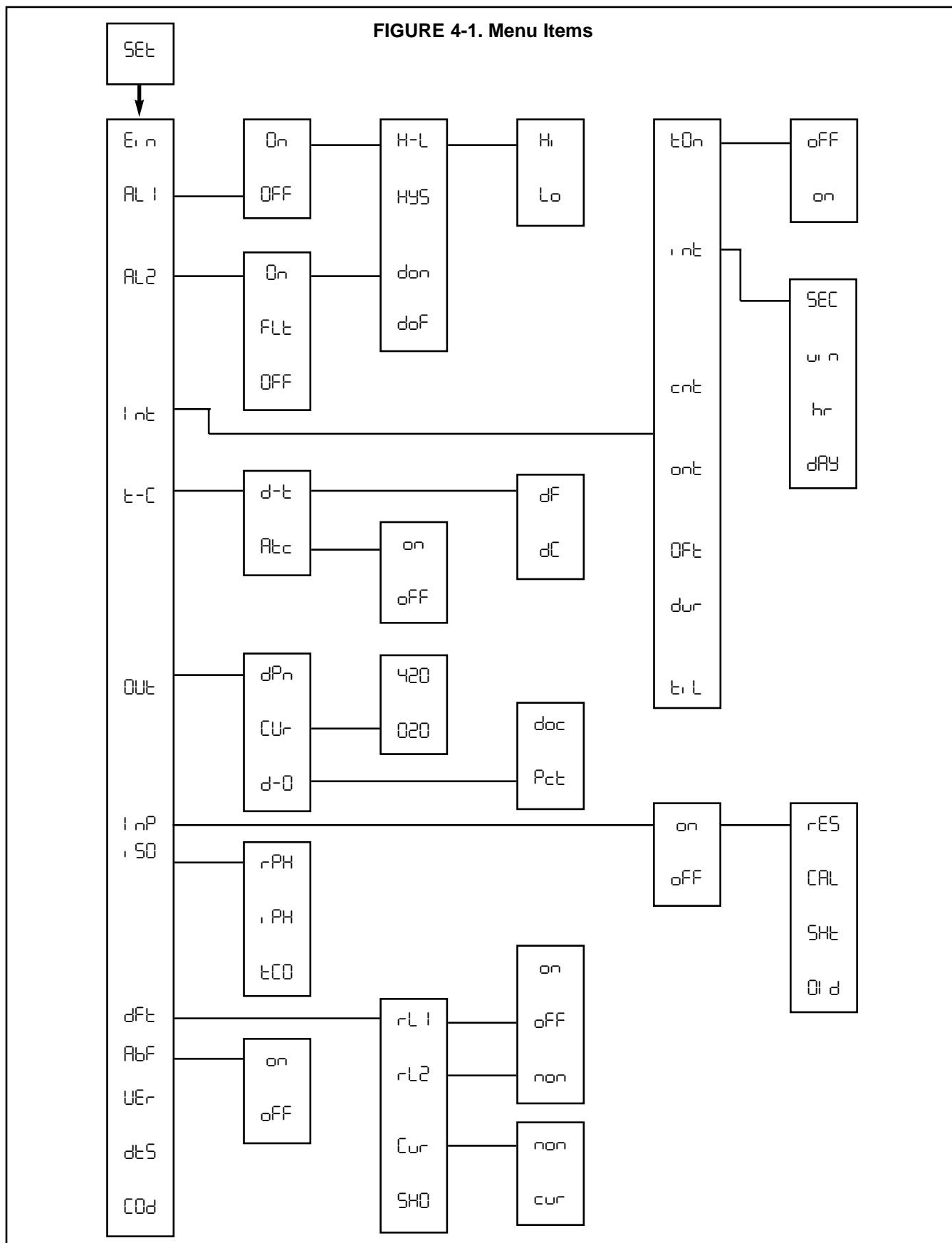

TABLE 4-1. Configuration Work Sheet

Use this work sheet to assist in the configuration of the analyzer.

Date: _____

	RANGE	FACTORY SET	USER SET
A. Alarm 1 Setup (AL1)			
1. Alarm Configuration (ON/OFF)		ON	_____
2. High or Low (H-L) (Hi /Lo)		Lo	_____
3. Hysteresis (HYS)	0-2.0 pH	0 pH	_____
4. Delay Time On (don)	0-255 sec.	000 Seconds	_____
5. Delay Time Off (doF)	0-255 sec.	000 Seconds	_____
B. Alarm 2 Setup (AL2)			
1. Alarm Configuration (ON/FLT/OFF)		ON	_____
2. High or Low (H-L) (Hi /Lo)		Hi	_____
3. Hysteresis (HYS)	0-2.0 pH	0 pH	_____
4. Delay Time On (don)	0-255 sec	000 Seconds	_____
5. Delay Time Off (doF)	0-255 sec	000 Seconds	_____
C. Interval Timer (Int)			
1. Active Status (tON) (OFF/on)		OFF	_____
2. Interval Time (int)	Minimum 10 Minutes	10 Seconds	_____
3. Count (cnt)	1 to 60	5	_____
4. On Time (ont)	0 to 299 sec	1 Second	_____
5. Off Time (offt)	0 to 299 sec	1 Second	_____
6. Duration (dur)	0 to 299 sec	2 Seconds	_____
D. Temperature Setup (t-C)			
1. Display Temperature (d-t) (dC/dF)		dC	_____
2. Automatic Temperature Compensation (ATC) (on/off)		on	_____
a. Manual Temp. Value	-10°C to 125°C		_____
E. Current Output Setup (OUT)			
1. mA Output (CUR) (020/420)		420	_____
2. Display Current Output (d-O) (Pct/dacc)		dacc	_____
3. Dampen Current Output (dPn)	0-255 sec.	0.0 Seconds	_____
F. Electrode Diagnostics Setup (t nP)			
1. Temp compensated impedance (r-ES)		(on off)	_____
2. Impedance increase before calibration (ICL)	20-200%	20%	_____
3. Cracked glass impedance low limit (5HL)	5-600 megohms	20 megohms	_____
4. Aged electrode impedance high limit (OI d)	200-1999 megohms	1000 megohms	_____
G. Default Setup (dFt)			
1. Relay 1 Default (r-L1) (non/off/on)		non	_____
2. Relay 2 Default (r-L2) (non/off/on)		non	_____
3. Current Output Default (CUR) (non/CUR)		non	_____
H. Automatic Buffer Mode (ABF)			
1. Configuration (on off)		on	_____
I. Keyboard Security Setup (CKD)			
1. Keyboard Security Required	001-999	-	_____
2. Keyboard Security Not Required	000	000	_____
Alarm Setpoints			
1. Alarm 1 (SP 1)	0-14 pH	0.00 pH	_____
2. Alarm 2 (SP 2)	0-14 pH	14.00 pH	_____
Current Output			
1. Zero (0 or 4 mA) (LO)	0-14 pH	0.00 pH	_____
2. F.S. (20 mA) (Hi)	0-14 pH	14.00 pH	_____

4.2 ALARM 1 AND 2. Display Mnemonic "AL 1" or "AL2". Used to set alarm relay logic. The alarms may be configured to perform on-off process control. See note below.

A. On. Display Mnemonic "ON". Select this item if Alarm 1 or 2 is to be used as a process alarm. See Steps D thru G for further alarm configuration.

B. Off. Display Mnemonic "OFF". Select this item if Alarm 1 or 2 will not be used as a process alarm or to temporarily disable either alarm. Alarm 1 or 2 setpoint will display "OFF" if this item is selected. Omit Steps C thru G.

C. Fault (Alarm 2 Only). Display Mnemonic "FLT". Select to make Alarm 2 energized when the analyzer detects a fault condition. See Table 8-1 for a listing of the fault mnemonics and their descriptions. Alarm 2 setpoint will display "F L T" if this item is selected. Omit Steps D thru G.

D. Alarm Logic. Display Mnemonic "H-L". Select this item for high or low alarm logic. High logic activates the alarm when the reading is greater than the set point value. Low logic activates the alarm when the reading is less than the setpoint value.

E. Relay Hysteresis. Display Mnemonic "HY5". Sets the relay hysteresis (dead band) for deactivation after reading has passed the alarm setpoint. May be set from 0 to 2.0 pH. Use hysteresis when a specific pH should be reached before alarm deactivation.

F. Delay Time On. Display Mnemonic "dOn". Sets time delay for relay activation after alarm setpoint is reached. May be set from 0 to 255 seconds.

G. Delay Time Off. Display Mnemonic "dOff". Sets time delay for relay deactivation after alarm setpoint is reached. May be set from 0 to 255 seconds. Alarm state restarts time from zero. Use when a fixed time should pass before relay deactivation occurs.

NOTE

Alarm logic may be changed from normally open (N.O.) to normally closed (N.C.) by cutting bowties on the power supply PCB and adding a jumper between W4 and W5, and or W6 and W7, and or W8 and W9.

4.2.1 Alarm Setup (AL 1/AL2).

1. Enter Set Mode by pressing **ACCESS** key twice.
2. **SCROLL** (▲) until "AL 1" or "AL2" appears on the display.
3. **SELECT** to move to the next menu level. "ON", "OFF" or (AL2 only) "FLT" will display.
4. **SCROLL** (▲) to display desired item then **SELECT**.
5. If "OFF" is selected, display will show "OFF" to acknowledge. Press **ENTER** key to return to "AL 1" or "AL2", concluding routine. Skip to Step 11.

If "ON" is selected, display will show "ON" to acknowledge, then display "H-L". Proceed to Step 6.

If "FLT" is selected, display will show "FLT" to acknowledge. Press **ENTER** key to return to "AL2".
6. **SELECT** "H-L". "H" or "LO" will display (flashing).
7. **SCROLL** (▲) to the desired item and **ENTER** it into memory. Display will return to "H-L". If changes to relay activation logic are desired, proceed to Step 8, otherwise Step 12.
8. **SCROLL** (▲) to display "HY5", "dOn" or "dOff", then **SELECT** desired item. The Numeric Display will flash to indicate that a value is required.
9. Use **SCROLL** (▲) and **SHIFT** (Ô) to display the desired value.
10. **ENTER** value into memory. Analyzer will acknowledge and return to display of last item selected. Repeat Step 8 if further changes are desired, otherwise Step 12.
11. Repeat Step 3 for the other Alarm's settings as required.
12. To return to the first level of the Set Mode, press the **ACCESS** key.

FIGURE 4-2. Alarms 1 and 2 Configuration

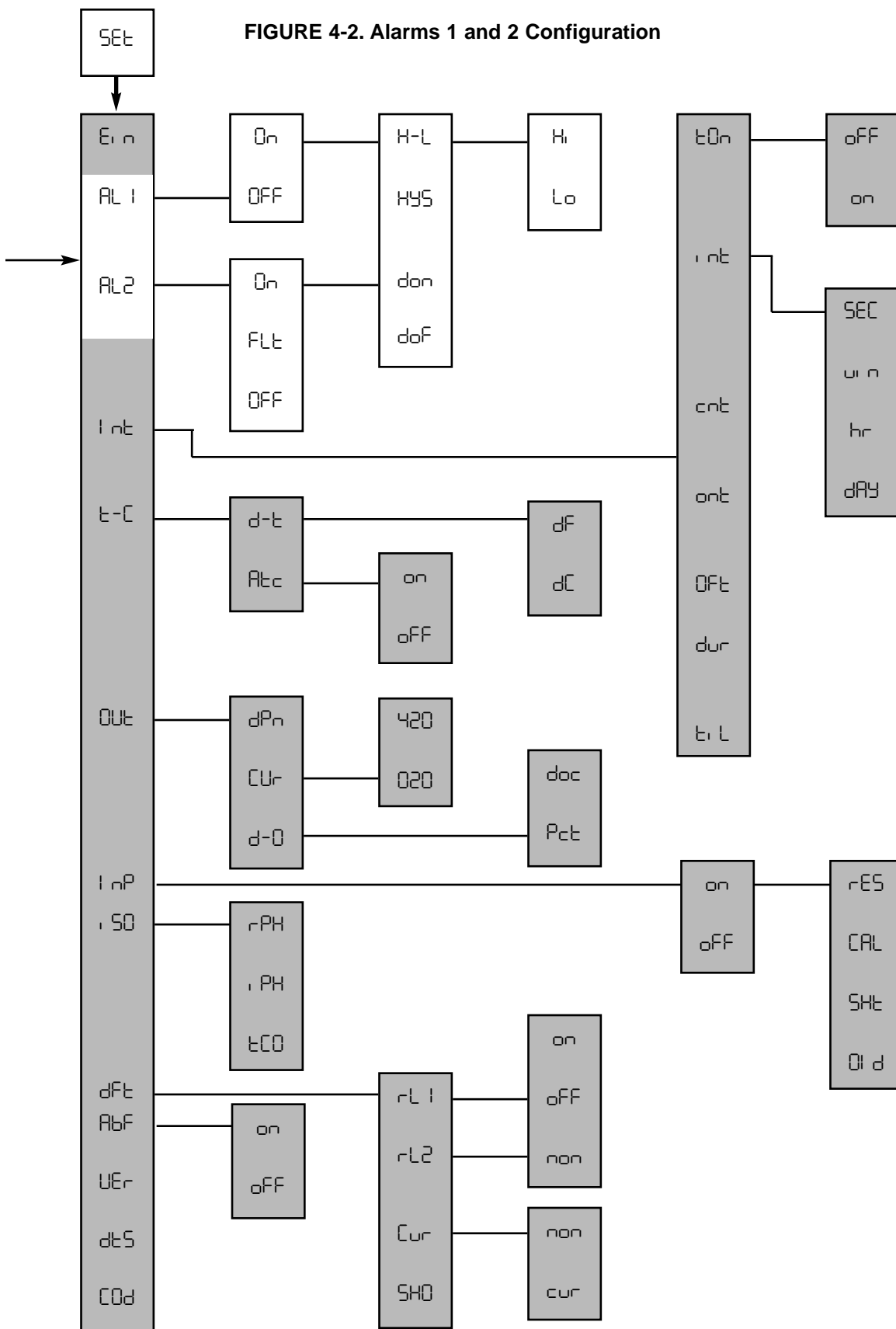

4.3 INTERVAL TIMER. Display Mnemonic `INT`. This item is used to set the interval timer's relay logic. The timer can be used for sensor maintenance, such as wash cycle or ultrasonic cleaner activation. Refer to Figure 4-3A.

A. Interval Timer Enable/Disable. Display Mnemonic `EN`. Select this item to begin interval cycle `ON` or disable interval cycle `OFF`.

B. Interval Period. Display Mnemonic `PER`. Select this item to set the time period between control cycles. `SEC` for seconds, `MIN` for minutes, `HR` for hours, and `DAY` for days. May be set from a minimum of 10 minutes.

C. Relay Activations Per Cycle. Display Mnemonic `CNT`. Select this item to enter the number of times the relay will activate per cycle. May be set from 1 to 60.

D. Relay Activation Duration. Display Mnemonic `ACT`. Select this item to enter the relay activation time for each `CNT`. May be set from 0 to 299 seconds.

E. Relay Deactivation Duration. Display Mnemonic `OFF`. Select this item to enter the relay deactivation time between each `CNT` during the control cycle. Valid when "CNT" is 2 or greater. May be set from 0 to 299 seconds.

F. Wait Duration. Display Mnemonic `DUR`. Select this option to enter the electrode recovery time after the last `CNT` in a cycle. May be set from 0 to 299 seconds. The duration can be used for electrode recovery after a wash cycle.

G. Interval Time Remaining. Display Mnemonic `EL`. Select this item to display the time remaining until the next control cycle. If selected during the control cycle, the display will show `---`.

NOTE

The Model 1054A pH is placed *on hold* during the control cycle (from first relay activation through the wait duration). The analyzer will simulate a fault condition and briefly show `---` every eight seconds. The display will continue to show the measured value.

4.3.1 Interval Timer Set Up (INT).

1. Enter Set Mode by pressing **ACCESS** key twice.
2. **SCROLL** (**▲**) until `INT` appears on the display.
3. **SELECT** to move to the next menu level. `EN` will display.
4. **SCROLL** (**▲**) to display `ON` or `OFF` and **ENTER** it into memory. If interval configuration is required, proceed to Step 5, otherwise Step 10.
5. **SCROLL** (**▲**) to display desired menu item. If `INT` is selected, proceed to Step 6, otherwise Step 10.
6. **SCROLL** (**▲**) to display desired interval period and **SELECT**. The Numeric Display will flash.
7. **SCROLL** (**▲**) and **SHIFT** (**Ô**) to display the desired value and **ENTER** it into memory. Display will return to interval period menu.
8. Repeat Steps 6 and 7 as needed.
9. Press the **ENTER** key to return to the main timer menu.
10. **SELECT** the desired item. The Numeric Display will flash.
11. **SCROLL** (**▲**) and **SHIFT** (**Ô**) to display the desired value and **ENTER** it into memory.
12. Repeat Steps 5, 10, and 11 as required.
13. Press the **ENTER** key to return to the Set Menu.

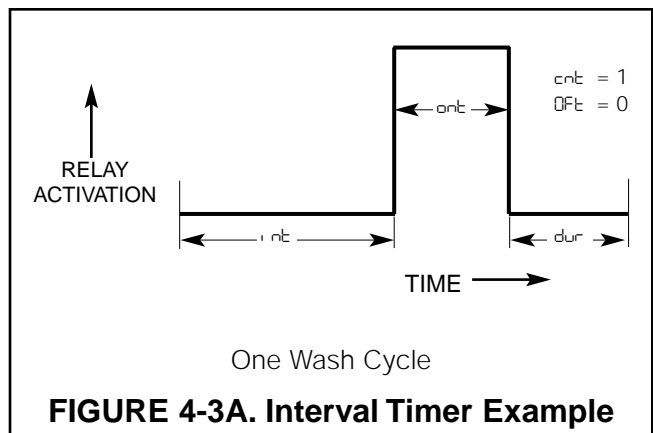
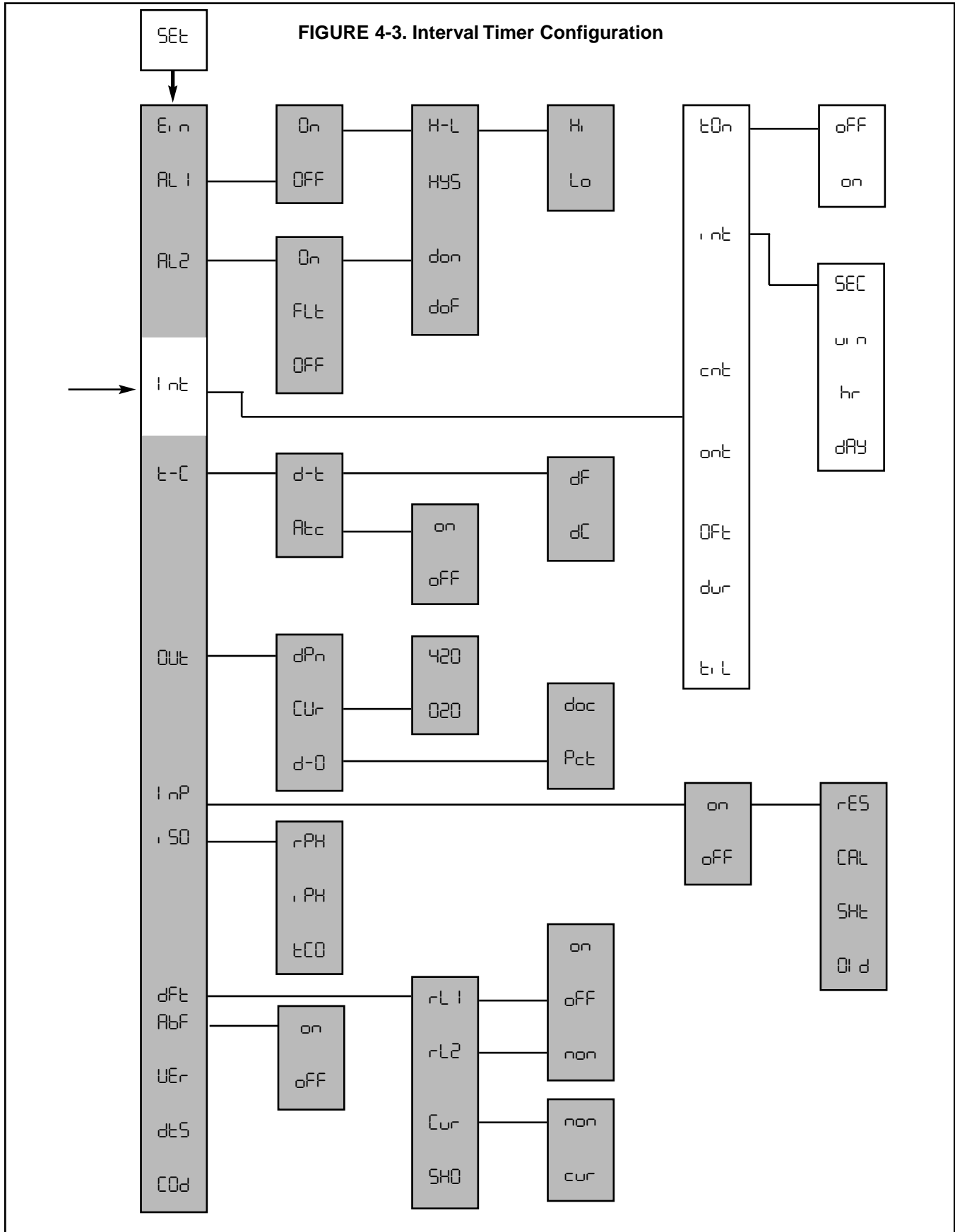

FIGURE 4-3. Interval Timer Configuration



4.4 TEMPERATURE. Display Mnemonic "T-C". Select this item for temperature reading and compensation choices.

A. Temperature Display. Display Mnemonic d-T . Select this item to toggle between °F and °C temperature display. The 1054A pH will show all temperatures in units selected until the selection is changed.

B. Automatic Temperature Compensation. Display Mnemonic ATC . The Model 1054A pH will use the temperature input from the sensor for temperature compensation when ON is selected. When OFF is selected, the analyzer will use the value entered by the user for temperature compensation. This manual temperature option is useful if the temperature sensor is faulty or not on line. Temperature specific faults (ECH and ECL 0 will be disabled. (Refer to Table 8-1.)

4.4.1 Temperature Setup (T-C).

1. Enter Set Mode by pressing **ACCESS** key twice.
2. **SCROLL** (▲) until "T-C" appears on the display.
3. **SELECT** to move to the next menu level. d-T will display.
4. **SCROLL** (▲) to display desired item, then **SELECT**.
5. If d-T is selected, display will show dC or dF .
If ATC is selected, display will show "ON" or "OFF".
6. **SCROLL** (▲) then **ENTER** desired item into memory.
7. If dC , dF or "ON" are entered, display will return to the previous level (proceed to Step 9).

If OFF is selected, the Numeric Display will flash indicating that a process temperature value is required (proceed to Step 8).
8. Use **SCROLL** (▲) and **SHIFT** (Ô) to display the desired value. **ENTER** value into memory.
9. Repeat Steps 4-8 as required for other item.
10. Press the **ENTER** key to return to Set Menu.

FIGURE 4-4. Temperature Configuration

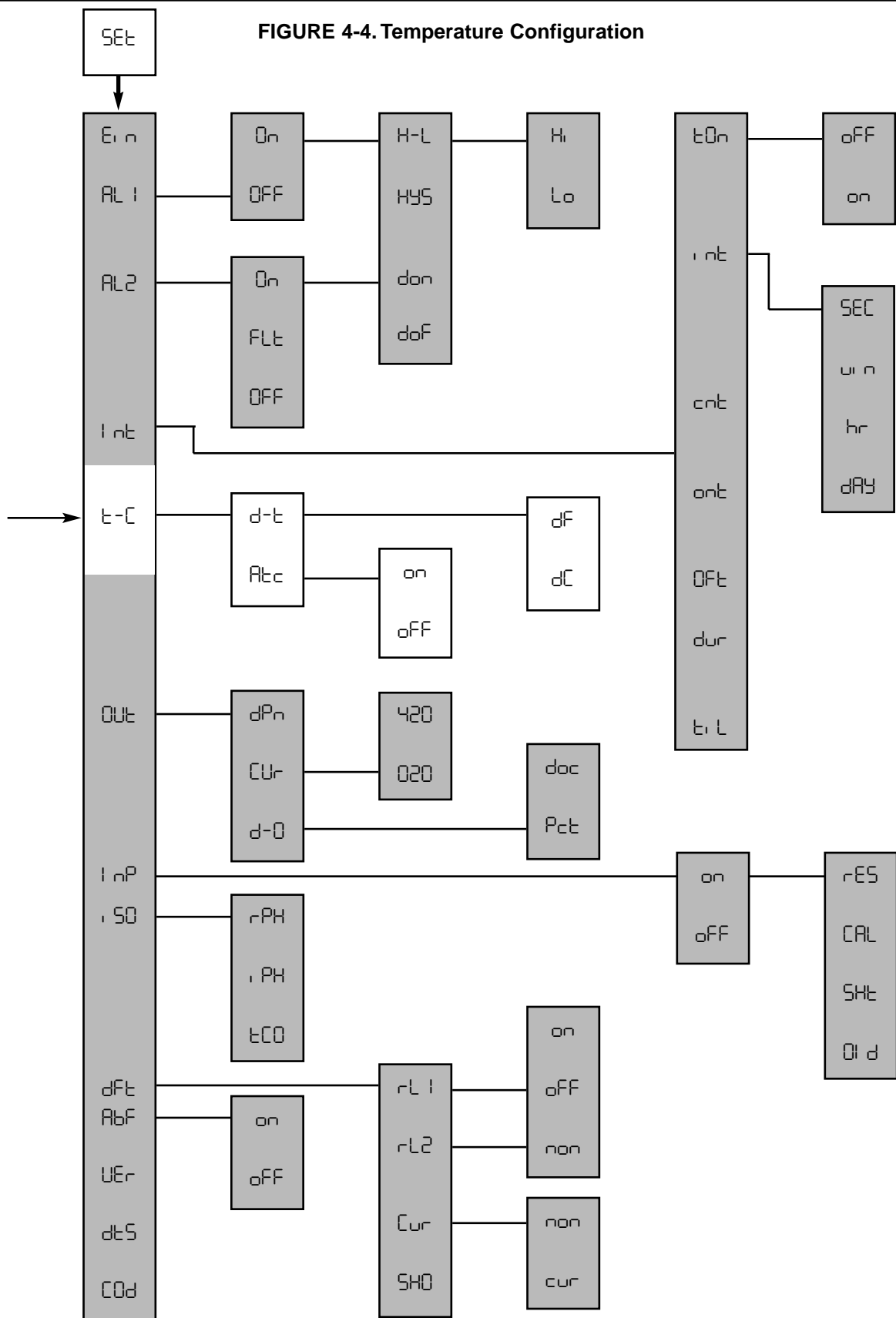

4.5 CURRENT OUTPUT. Display Mnemonic "OUT". This item is used to configure the current output signal.

A. Output Dampening. Display Mnemonic dPn . Dampens the response of the signal output. This option is useful to minimize the effect of a noisy reading. The number entered is the sample time (in seconds) for an averaged output. Zero to 255 seconds may be entered.

B. mA Output Range. Display Mnemonic CUr . Selection of this item will allow choice of 0 to 20 mA or 4 to 20 mA output range.

C. Display Output. Display Mnemonic $d-O$. This item is used to select logic of output display. Selecting this item will allow the 1054A pH to display current output as mA dOC or as a percent of full scale output range Pct .

4.5.1 Output Setup (OUT).

1. Enter Set Mode by pressing the **ACCESS** key twice.
2. **SCROLL** (\blacktriangle) until OUT appears on the display.
3. **SELECT** to move to the next menu level. dPn will display.
4. **SCROLL** (\blacktriangle) then **SELECT** desired item.
5. If dPn is selected, the Numeric Display will flash indicating that a value is required. Proceed to Step 6.
If CUr or $d-O$ is selected, proceed to Step 7.
6. **SCROLL** (\blacktriangle) then **SHIFT** (\hat{O}) to display the desired value. **ENTER** into memory.
7. **SCROLL** (\blacktriangle) then **ENTER** desired item.
8. Repeat Steps 4-7 as required.
9. Press the **ENTER** key to return to the Set Menu.

FIGURE 4-5. Current Output Configuration

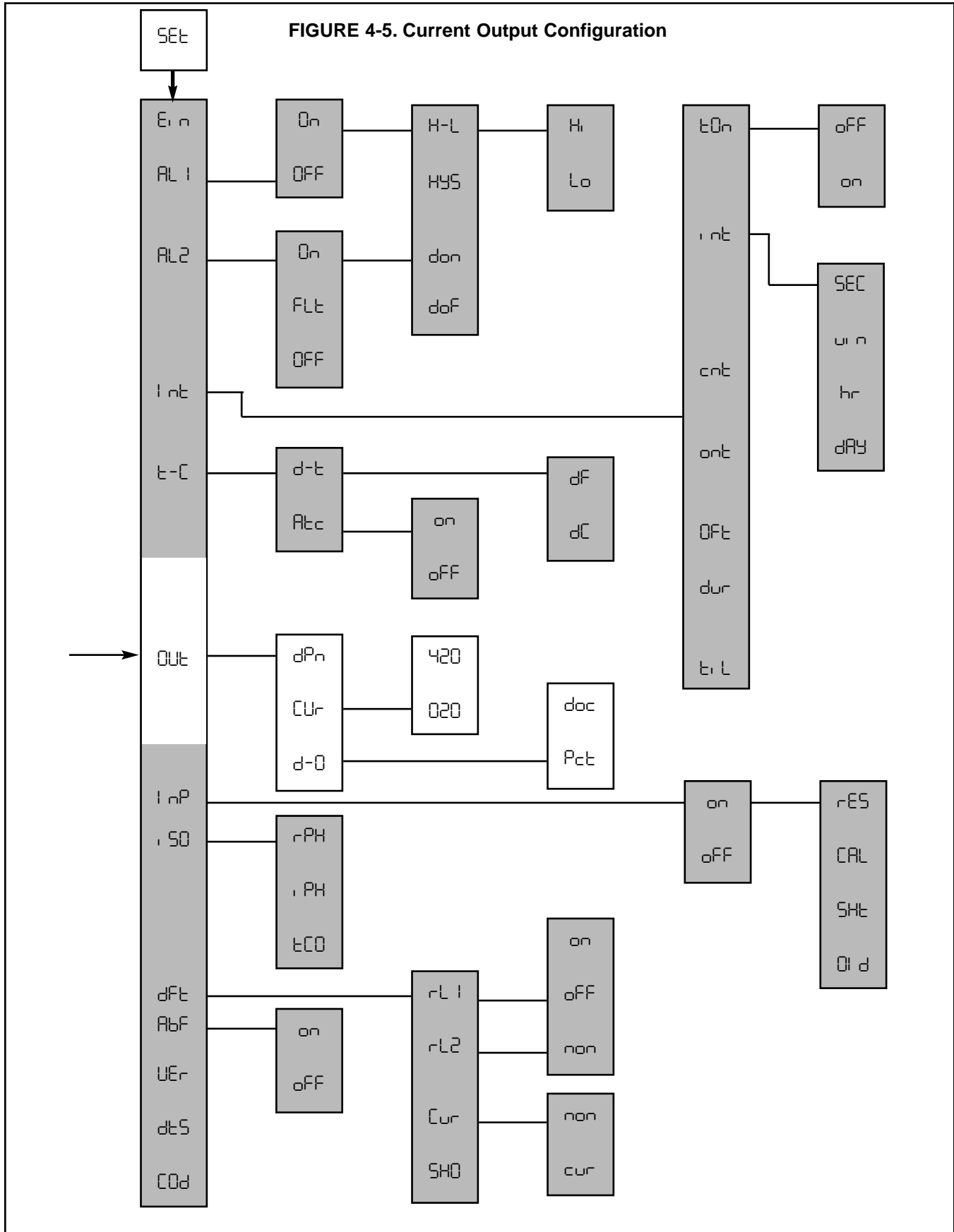

4.6 pH ELECTRODE DIAGNOSTICS. Display Mnemonic "I nP". Under this item are functions associated with glass electrode diagnostics. These diagnostics are possible through a continuous, temperature compensated measurement of the sensor impedance (resistance), "rE5", made from the preamp. **A software selectable "on" setting will activate these diagnostics. If "off" is the setting (factory setting) these diagnostics will all be disabled.**

A new electrode has an impedance of approximately 200 megohms, and as it ages the impedance increases because lithium ions (which carry current) in the glass slowly get depleted by the process. If an electrode cracks, the impedance drops sharply, usually to below 70% of the normal value.

The following are typical impedance values for **new** Rosemount Analytical electrodes (Electrodes stored over a period of time will have higher impedances). Upon installation you can read impedance in megohms under "rE5".

<u>Sensor/Glass Type</u>	<u>Megohms @ 25°C (77°F) when new</u>
• General purpose, HF, and high pH glass	80-400
• Low impedance glass	40-150
• Ruggedized glass	300-600

For more information on these diagnostics and troubleshooting, refer to section 8.0.

NOTE

Impedance diagnostic faults are not activated until the setpoint is continuously exceeded for 30 seconds.

A. Calibration Warning. Display Mnemonic "CAL". Under this mnemonic you can select the percent increase in impedance before a calibration warning fault appears. For example, if the impedance is 400 megohms and the setpoint is 20% (factory setting), a "CAL" warning will appear on the analyzer and it will go into a fault mode when the electrode ages to 480 megohms. This diagnostic will reset after a buffer calibration. Configurable range: 20-200%. A setting of zero disables this fault.

NOTE

The recommended process temperature range for the "CAL" diagnostic is 15-90°C (15-194°F). (For low impedance glass it is 15-80°C (59-176°F). If ruggedized glass is used and the preamp is not in the sensor, the minimum recommended temperature is 35°C (95°F).

If you want to use this feature as a warning yet not upset your process, use Alarm 2 as a fault alarm (Refer to Section 4.2) and set the default current output to "non" (Refer to Section 4.8) to hold the output at the last process value.

You may also get this fault if:

1. The electrode or junction becomes excessively coated.
2. The electrode is not immersed in the process fluid. If the electrode continues to remain out of solution eventually the fault mnemonic "E d" will also appear on the display. See part C.

B. Cracked Glass Diagnostic. Display Mnemonic "5HE". One way to tell that you have a broken or cracked glass electrode is that the analyzer will read a constant value (usually between 5.0-7.0 pH) in any process or buffer. The other way is to note the impedance value. When a crack occurs the mnemonic "5HE" will appear on the analyzer to indicate that the circuit is shorted, and the analyzer will go into a fault mode. Directions for "5HE" value determination:

$$"5HE" \sim 70\% \text{ of normal } "rE5"$$

Configurable range: 5-600 megohms. A setting of zero disables this fault. Factory setting: 20 megohms.

NOTE

For low impedance glass, a broken electrode may not be detectable above 70-75°C (158-167°F).

C. Worn Out Electrode. Display Mnemonic "E d". This mnemonic is used for programming the high impedance limit of the electrode. For example, if the setpoint is 1000 megohms (factory setting), and the impedance rises above this value, the mnemonic "E d" will appear on the analyzer and it will go into a fault mode. The electrode is either worn out, severely coated, or not immersed in the process fluid. Configurable range: 200-1999 megohms. A setting of zero disables this fault.

Recommended setpoints:

1. 1000 megohms for all glass except ruggedized
2. 1300 megohms for ruggedized glass

FIGURE 4-6. pH Electrode Diagnostics Configuration

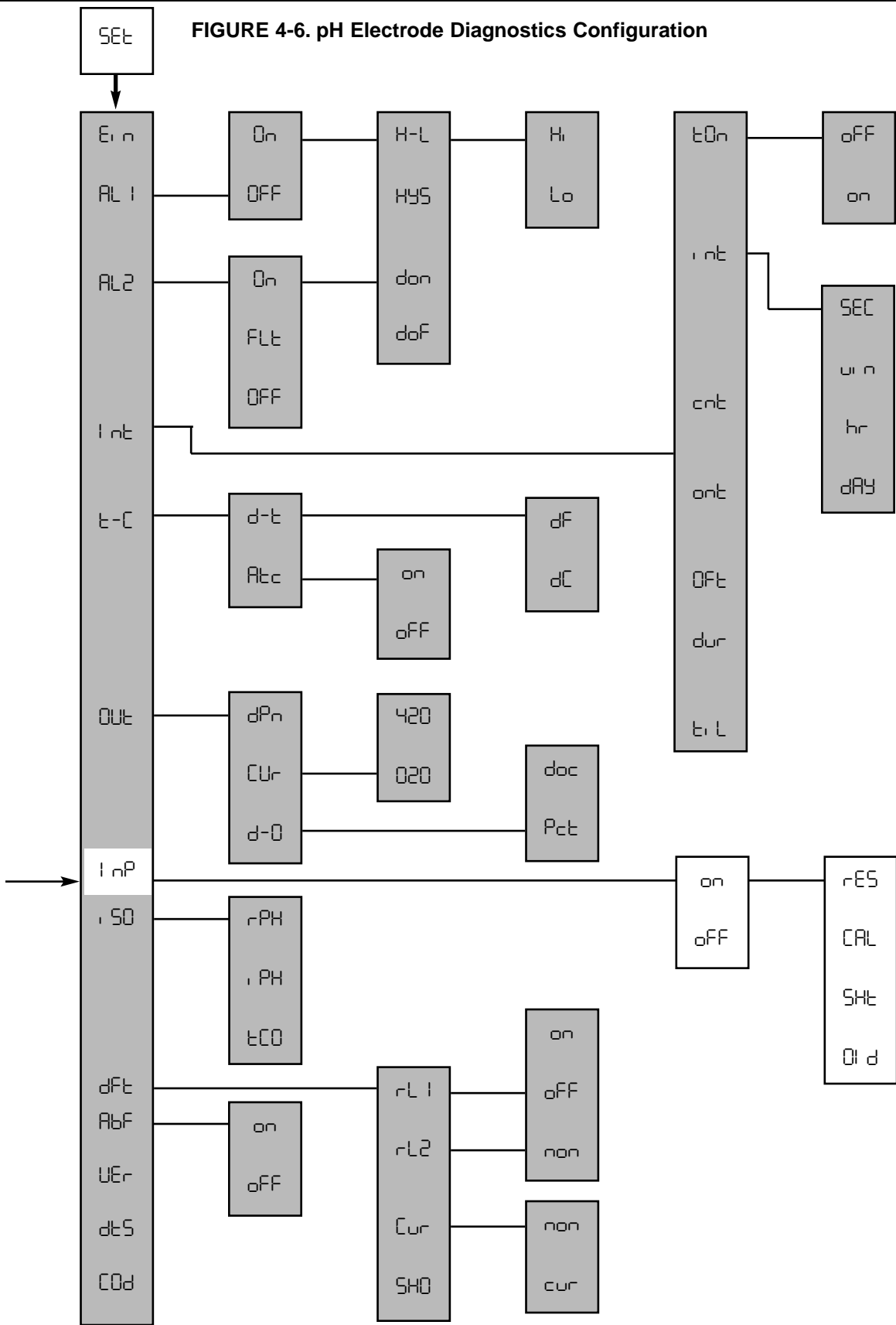

4.6.1 pH Electrode Diagnostics Setup

1. Enter the Set Menu by pressing the **ACCESS** key twice.
2. **SCROLL** (⌵) until "i nP" appears on the display and **SELECT**.
3. "on" or "oFF" will display. If necessary, **SCROLL** (⌵) to the desired mnemonic then **ENTER**. "on" activates the diagnostics features.
4. If "oFF" is entered you can press the **ENTER** key to return to the main set menu or press the **pH** key to read pH.
If "on" is entered, the display will show "rES". Proceed to Step 5.
5. **SCROLL** (⌵) to display "rES", "CAL", "SHE", or "Di d", then **SELECT** the desired item. "rES" is a read only function. If "CAL", "SHE", or "Di d" is selected, the right most digit of the Numeric Display will flash to indicate that the value can be changed.
6. Use the **SCROLL** (⌵) and **SHIFT** (⌶) keys to change the value, if desired.
7. **ENTER** the value into memory.
8. Press **ENTER** to return to the main Set Menu.

4.7 SOLUTION TEMPERATURE COMPENSATION AND ISOPOTENTIAL POINT.

Display Mnemonic "i 50". Used for applications where the process' isopotential point ("i PH") and temperature coefficient ("tCC") are not standard. For normal pH measurements these values should be: "rPH" = 7.00 (normal process pH), "i PH" = 7.00 pH, "tCC" = 0.00 pH/°C. *These values should only be changed for special applications.*

Solution temperature compensation is designed to correct for changes in the actual pH of a solution caused by changes in dissociation with temperature. During standardization (section 5.4), if the sample pH is greater than about 6.5 and the lab test is run at a substantially different temperature than the process, determine a value for "tCC" in pH/°C and enter that value. The "tCC" should be determined over as narrow a temperature operating range as possible.

The isopotential point is the pH value at which temperature changes do not affect the pH reading.

The analyzer method requires the user to enter the normal process pH ("rPH") and the temperature coefficient ("tCC"), then the isopotential point ("i PH") will be calculated. Conversely, entering the normal process pH and the isopotential point causes the temperature coefficient to be calculated.

4.7.1 pH Measurement in High Purity Water with Ammonia Present.

The special characteristics of this measurement require changing isopotential pH value and temperature coefficient used by the Model 1054A pH. The reference pH (rPH) is the user's normal process pH. The isopotential pH value (i PH) of high purity water with ammonia is 16.84 pH. The temperature coefficient "tCC" is - 0.033 pH/°C.

4.7.2 Isopotential Point Set Up (i 50).

1. Enter Set Mode by pressing the **ACCESS** key twice.
2. **SCROLL** (▲) to display "i 50" and **SELECT**.
3. **SCROLL** (▲) to the desired menu item and **SELECT**. The Numeric Display will flash.
4. **SCROLL** (▲) and **SHIFT** (⌶) to display the desired value and **ENTER** it into memory.
5. Repeat Steps 3 and 4 as required.
6. Press the **ENTER** key to return to the Set Menu.

FIGURE 4-7.
Solution Temperature Compensation and
Isopotential Point Configuration

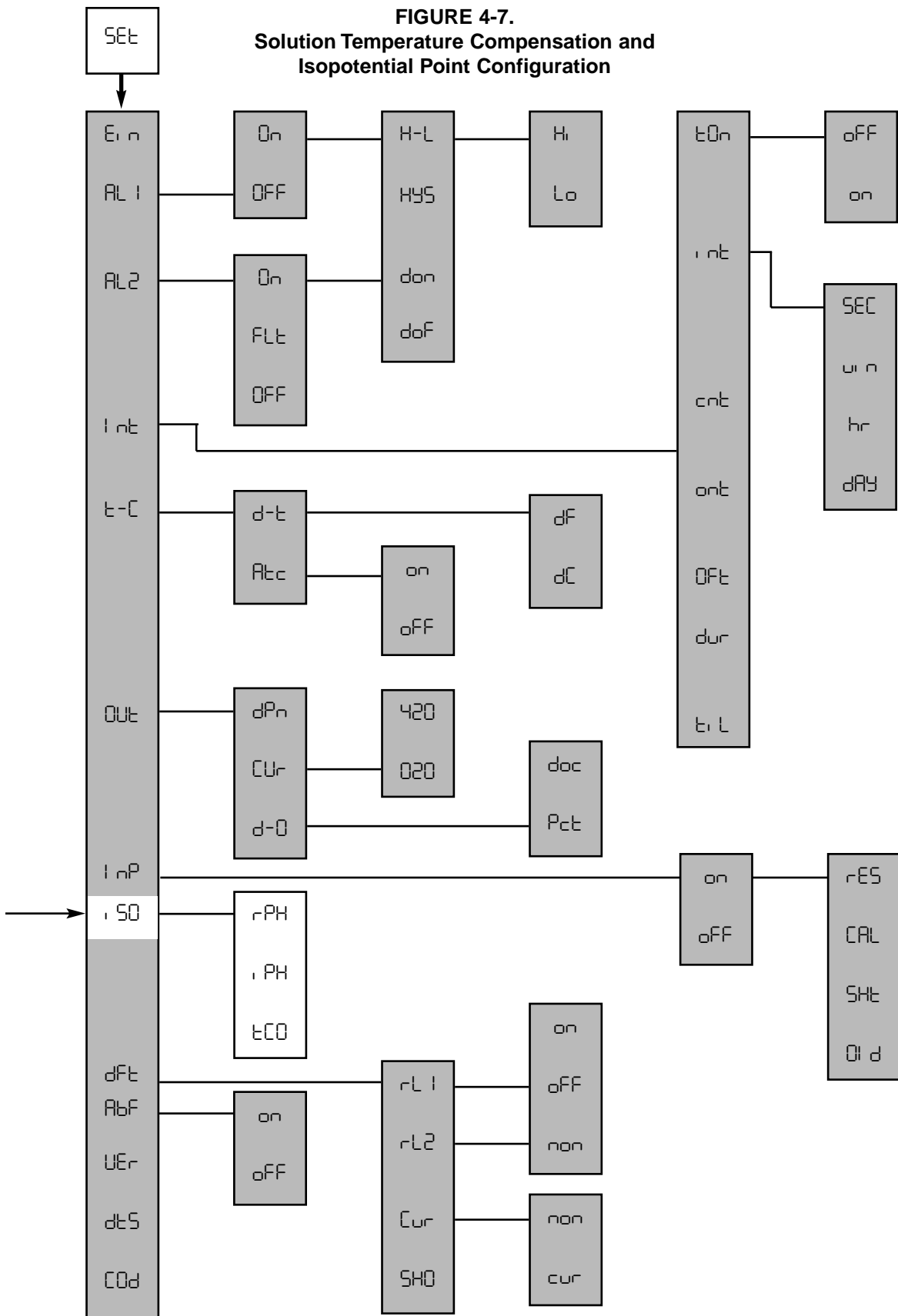

4.8 DEFAULTS. Display Mnemonic `dFt`. This item is used to set the configuration of relays and output default conditions during fault or hold status. See Table 8-1 for a listing of the possible fault conditions which can be diagnosed by the analyzer.

A. Relay 1 and 2. Display Mnemonic `rL1` and `rL2`. During a fault or hold condition the relays can be set to activate `on`, deactivate `off`, or remain in the state determined by the last process value `non`. See Table 4-2.

B. Current Output. Display Mnemonic `cur`. The current output is held at the last process value `non` or goes to a specified value in mA `cur` during a fault or hold condition.

C. Fault History. Display Mnemonic `SHD`. Select (⊙) this item will sequence the display through all faults detected in most recent fault mode. Press the **SCROLL**(▲) key once for previous fault mode list. Pressing **ACCESS** will clear `SHD` history.

4.8.1 Default Setup (dFt).

1. Enter Set Mode by pressing the ACCESS key twice.
2. **SCROLL** (▲) until `dFt` appears on the display.
3. **SELECT** to move to the next menu level. `rL1` will display.
4. **SCROLL** (▲) then **SELECT** desired item.
5. Display will show next item selection. **SCROLL** (▲) and **ENTER** desired item.
6. Repeat Steps 4 and 5 as required for other default settings `rL2` and `cur`. If `cur` is selected for `cur` press **ENTER**, then use the **SCROLL** (▲) and **SHIFT** (⊙) keys to enter the desired current value for a fault or hold condition.
7. Press the **ENTER** key to return to Set Menu.

TABLE 4-2. Relay States for Various Analyzer Conditions and Alarm/Default Configurations

Set menu default (dFt) setting <code>rL1</code> <code>rL2</code>	ANALYZER CONDITION								
	NORMAL			HOLD			FAULT		
	Set menu <code>AL1</code> <code>AL2</code> setting			Set menu <code>AL1</code> <code>AL2</code> setting			Set menu <code>AL1</code> <code>AL2</code> setting		
	<code>on</code>	<code>off</code>	<code>FLt</code> (Alarm 2 only)	<code>on</code>	<code>off</code>	<code>FLt</code> (Alarm 2 only)	<code>on</code>	<code>off</code>	<code>FLt</code> (Alarm 2 only)
<code>on</code>	Proc. det.	-	-	+	-	-	+	-	+
<code>off</code>	Proc. det.	-	-	-	-	-	-	-	+
<code>non</code>	Proc. det.	-	-	Proc. det.	-	-	Proc. det.	-	+

Proc. det.: Alarm state is determined by the process value

- + : Relay will activate
- : Relay will not activate

Example: If you want the analyzer to activate relay 1 in hold mode during buffer calibration, set "AL 1" to "on" in Section 4.2, and set "rL 1" to "on".

FIGURE 4-8. Default States Configuration

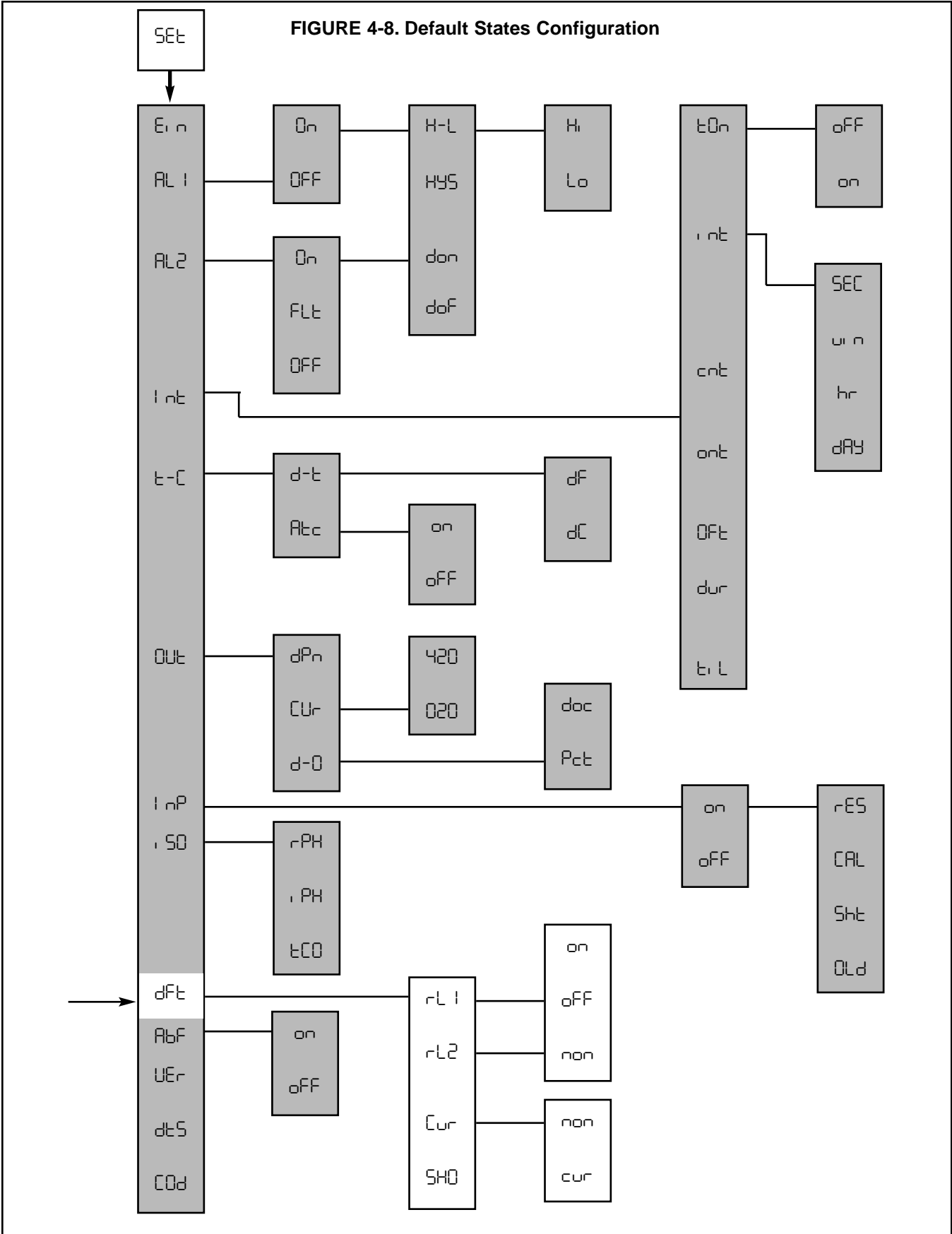

4.9 AUTOMATIC BUFFER MODE. Display Mnemonic ABF . Software selectable ON or OFF . **Factory setting is ON .** With the OFF setting, calibration is performed according to section 5.3.2, without automatic recognition and temperature compensation of the buffers.

The automatic buffer calibration feature (ON setting) provides automatic recognition of up to three of the buffers listed below (selectable in section 5.3.1). In addition, each buffer selection incorporates a temperature curve from 0-50°C so that the user does not need to determine the correct buffer pH which corresponds to the buffer temperature (for best accuracy in extreme temperature environments).

The stored buffer-temperature curves were generated from reference data according to NBS (National Bureau of Standards - U.S.), DIN 19266 (Germany), BSM (British Standards Method), and JIS 8802 (Japan) standards. The buffers are supplied by a wide variety of vendors.

NOTE

If any buffers other than those listed here will be used (such as some Fisher or Ingold buffers), the ABF setting should be OFF and calibration instructions followed in section 5.3.2.

4.9.1 Automatic Calibration Setup.

1. Enter the Set mode by pressing the **ACCESS** key twice.
2. **SCROLL** (D) until ABF appears on the display.
3. Press **SELECT**. ON or OFF will be displayed.
4. Press **SCROLL** (D) if the desired item is not displayed. Then press **ENTER**. You will be returned to the set menu.

Buffer Value at 25°C	Standards Referenced	Buffer Composition	Factory Selection
1.68	NBS, DIN 19266, JIS 8802	0.05M K tetroxalate	
3.56	NBS, BSM	KH tartrate (sat'd @ 25°C)	
3.78	NBS	0.05M KH_2 citrate	
4.01	NBS, DIN 19266, BSM, JIS 8802	0.05M KH Phthalate	*
4.64	BSM	0.1M HOAc 0.1M NaOAc	
6.86	NBS, DIN 19266, BSM, JIS 8802	0.025M KH_2PO_4 0.025M Na_2HPO_4	*
7.41	NBS, JIS, 8802	0.0087M KH_2PO_4 0.0302M KH_2HPO_4	
9.18	NBS, DIN 19266, BSM, JIS 8802	0.01M $\text{Na}_2\text{B}_4\text{O}_7$	*
10.01	NBS, BSM, JIS, 8802	0.025M NaHCO_3 0.025M Na_2CO_3	
12.45	NBS, DIN 19266	$\text{Ca}(\text{OH})_2$ (sat'd @ 25°C)	

FIGURE 4-9. Automatic Buffer Mode Configuration

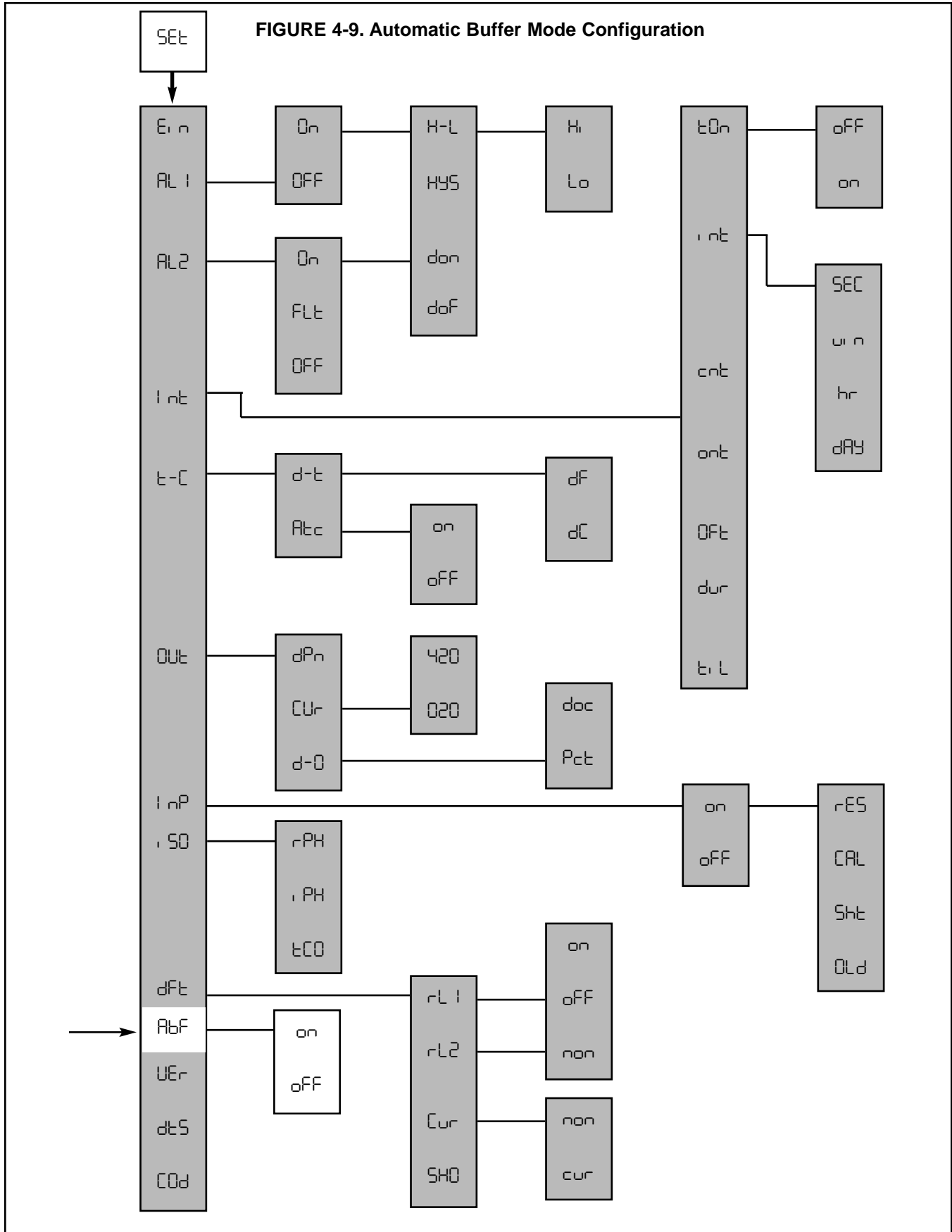

4.10 ALARM SETPOINT. The alarm setpoints should be adjusted after completing the configuration procedure as outlined in Sections 4.2 to 4.9.

1. Press the **pH** key to ensure that the analyzer is not in Set Mode.
2. Press the **ALARM 1** or **ALARM 2** key. "SP 1" or "SP 2" will show briefly, followed by the Alarm 1 or Alarm 2 setpoint.

3. **SELECT** to adjust the value. The display will acknowledge briefly with **Adj** followed by the Numeric Display with digit flashing.
4. **SCROLL (▲)** and **SHIFT (◐)** to display the desired value.
5. **ENTER** value into memory.
6. Repeat Steps 2 to 5 for the second setpoint.

NOTE

If the alarm is set to OFF or FAULT (Alarm 2 only), the analyzer will display OFF or FLt respectively. (Refer to Section 4.2.2, Alarm Setup.)

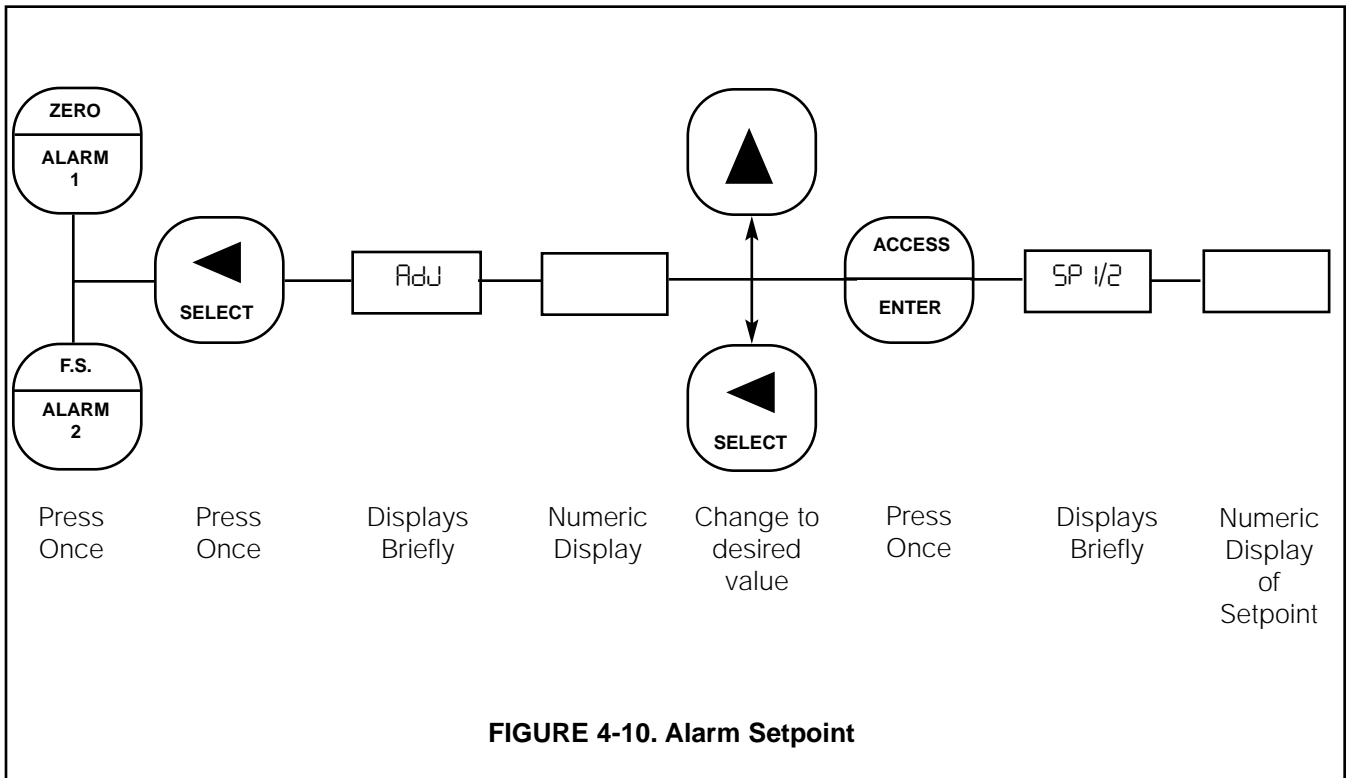

4.11 OUTPUT SCALE EXPANSION. This section should be followed if it is desired to scale the current output to an operating range other than the factory setting of 0-14 pH full scale. The output zero and full scale value should be adjusted after completing the configuration procedure as outlined in Sections 4.2 to 4.9.

A. Zero Point (0 mA or 4 mA)

1. Press the **pH** key to ensure that the analyzer is not in Set Mode.
2. Press the **ALARM 1** key twice. The display will show "LO" briefly then display ZERO point.
3. **SELECT** to adjust the value. The display will acknowledge briefly with **Adj** followed by the Numeric Display with digit flashing.
4. **SCROLL (▲)** and **SHIFT (◌)** to display the desired value.
5. **ENTER** value into memory. The display will show "LO" and display the entered value.

B. Full Scale (F.S.) Point (20 mA)

1. Press the **pH** key to ensure that the analyzer is not in Set Mode.
2. Press the **ALARM 2** key twice. The display will show **HI** briefly then display FULL SCALE point.
3. **SELECT** to adjust the value. The display will acknowledge briefly with **Adj** followed by the Numeric Display with digit flashing.
4. **SCROLL (▲)** and **SHIFT (◌)** to display the desired value.
5. **ENTER** value into memory. The display will show **HI** and display the entered value.

NOTE

For a reverse output, enter the higher value for zero, and the lower value for the Full Scale.

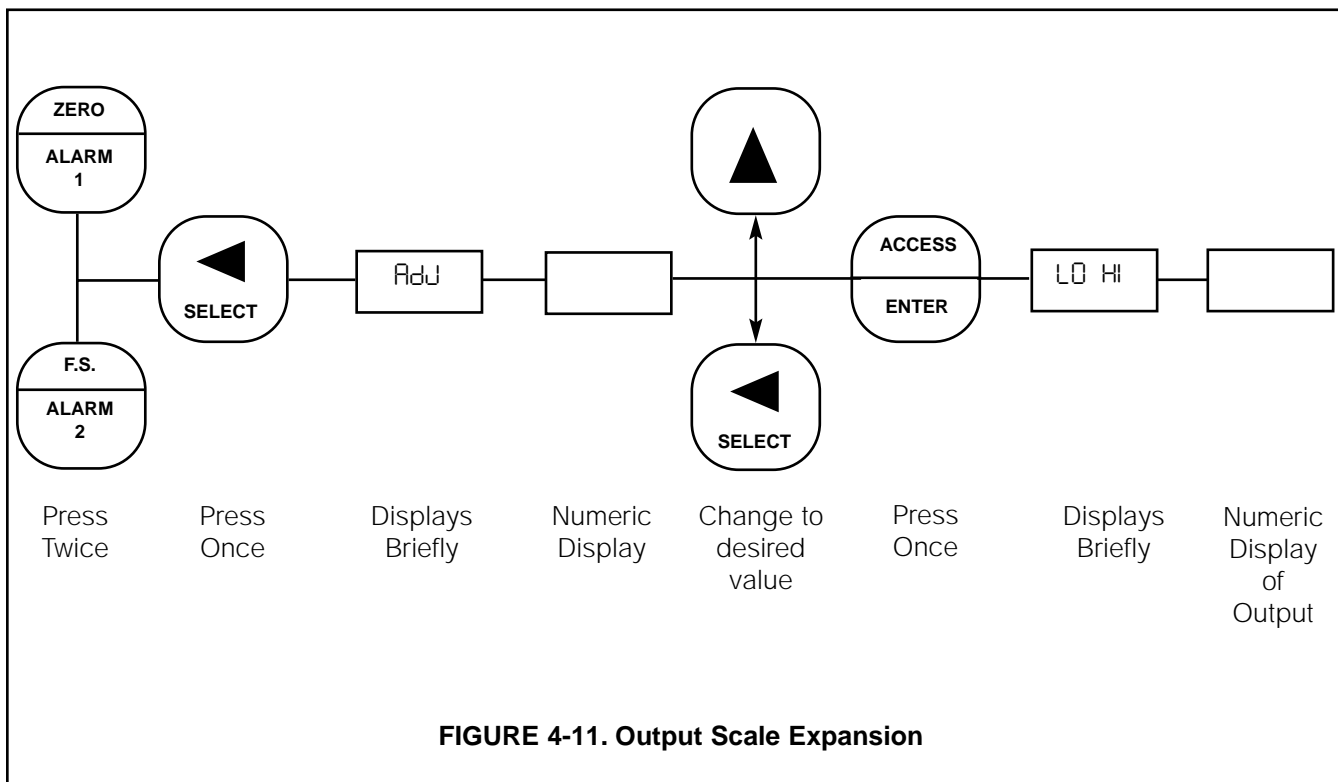

4.12 SIMULATE CURRENT OUTPUT. The output can be simulated to check the operation of devices such as valves, pumps, or recorders. The output can be simulated in either current (mA) or percent of full scale, depending on how the output display, "d-o-c", was configured in Section 4-5. (Refer to Figure 4-12.)

A. Simulate Output in Percent "S, P". The output can be simulated in percent if "d-0" in Section 4.5 was configured to display percent "Pct".

1. Press the **pH** key once to insure that the analyzer is not in the Set Mode.
2. Press **OUTPUT** key twice. The display will show "Pct" briefly, then display the output value in percent of full scale.
3. Press the **SELECT** (◀) to simulate the output. The display will briefly acknowledge with "S, P" followed by the Numeric Display with digit flashing.
4. **SCROLL** (▲) and **SHIFT** (◊) to display the desired value.
5. **ENTER** value into memory. The display will show "Pct" and display the entered value. Also, the display will flash to acknowledge that the analyzer is placed on hold "HLd".
6. To remove the analyzer from hold, press the **HOLD** key twice. The hold flag on the display will be removed and the display will stop flashing.

B. Simulate Output in Current "S, C". The output can be simulated in mA units if "d-0" in Section 4.5 was configured to display current "doc".

1. Press the **pH** key once to insure that the analyzer is not in the Set Mode.
2. Press the **OUTPUT** key twice. The display will show "doc" briefly, then display the output value in mA.
3. Press **SELECT** (◊) to simulate the output. The display will briefly acknowledge with "S, C" followed by the Numeric Display with digit flashing.
4. **SCROLL** (▲) and **SHIFT** (◊) to display the desired value.
5. **ENTER** value into memory. The display will show "doc" and display the entered value. Also, the display will flash to acknowledge that the analyzer is placed on hold "HLd".
6. To remove the analyzer from hold, press the **HOLD** key twice. The hold flag on the display will be removed and the display will stop flashing.

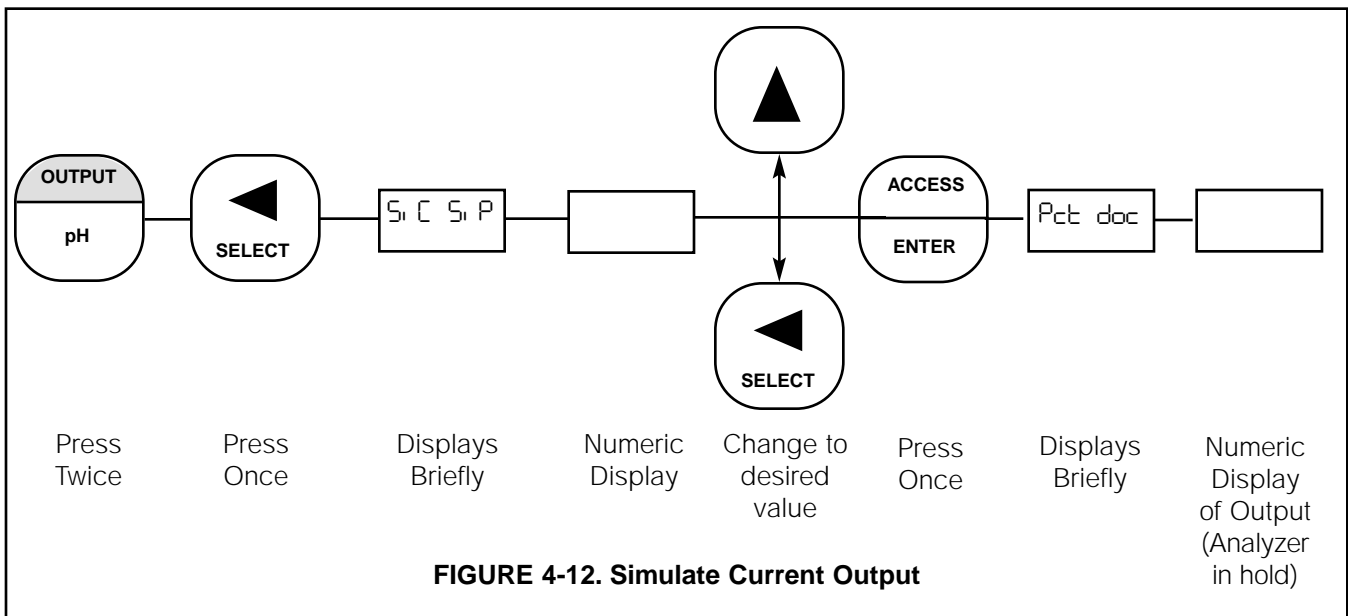

FIGURE 4-12. Simulate Current Output

SECTION 5.0

START-UP AND CALIBRATION

5.1 START-UP AND CALIBRATION. Calibration and operation of the Model 1054A pH should begin only after completion of configuration of the analyzer. The sensor must be wired to the Model 1054A pH for calibration.

5.2 Temperature Calibration. For accurate temperature correction, the temperature reading may need adjusting. The following steps should be performed with the sensor in a grab sample or in the process. For the best accuracy, the standardization should be performed at or near the process temperature.

1. Observe the analyzer temperature reading by pressing the **TEMP** key. Allow the reading to stabilize to insure that the sensor has acclimated to the process temperature.
2. Compare the reading to a calibrated temperature reading device. If the reading requires adjusting, proceed to Step 3.
3. Press the **TEMP** key then the **SELECT** key to correct the temperature display. The analyzer will display "Adj" briefly, then the Numeric Display will show with digit flashing.
4. **SCROLL** (▲) and **SHIFT** (Ô) to key in the correct value and **ENTER** it into memory. Proceed to Section 5.3.

5.3 BUFFER CALIBRATION. The two buffer calibration will calculate the slope (efficiency) of the pH sensor and standardize the reading on the second buffer (computed slope limits: 47.3 to 59.9 mV/pH). The analyzer has been set at the factory for automatic calibration. If the software setting has been changed to disable this feature in section 4.9 proceed to section 5.3.2. Otherwise, proceed to section 5.3.1.

5.3.1 Automatic Calibration

1. Press the **HOLD** key twice to place the analyzer in hold.
2. Obtain two buffer solutions with values at least two pH units apart. Unopened buffers have a shelf life of about a year and once opened should generally not be reused because of possible contamination.
3. Shake the sensor down to remove entrapped air bubbles from the glass electrode tip.
4. Place the sensing portion of the pH sensor into a beaker containing the first buffer solution. Allow the pH reading to stabilize. This may take several minutes, as the pH sensor may need to cool down to the buffer temperature. If you don't wait long enough you may get a slope error.
5. Press the **CAL** key. "Ab 1" will flash briefly, followed by a flashing pH buffer value at 25°C (If "Ab 2" appears, press the **CAL** key again for "Ab 1").
6. If the value displayed is not the value of your buffer at 25°C (see section 4.9) press the **SCROLL** (Ð) key until your choice appears. **ENTER** the value.
7. Remove the sensor from the buffer, then rinse and dry it. Place it in the second buffer. Allow the pH reading to stabilize. This may take several minutes, as the pH sensor may need to cool down to the buffer temperature. If you don't wait long enough you may get a slope error.
8. Press the **CAL** key again. "Ab 2" will display briefly, followed by a flashing pH buffer value at 25°C. (If "Ab 1" appears, press the **CAL** key again for "Ab 2").
9. If the value displayed is not the value of your buffer @ 25°C, press the **SCROLL** (Ð) key until your choice appears. **ENTER** the value.
10. Press the **HOLD** key twice again to remove the analyzer from hold.
11. In the future the selected buffers will be recognized by the analyzer and can be used for either "Ab 1" or "Ab 2".
12. For maximum accuracy, perform a process standardization after a buffer calibration (see Section 5.4). Also, you can track your electrode slope value after a buffer calibration to see how the electrode is aging (see Section 5.5).

5.3.2 Calibration With Automatic Features Disabled.

1. Press the **HOLD** key twice to place the analyzer in hold.
2. Obtain two pH buffer solutions with values at least two pH units apart. Unopened buffers have a shelf life of about a year and once opened they should generally not be reused because of possible contamination.
3. Shake the sensor down to remove entrapped air bubbles from the pH glass electrode tip.
4. Place the sensing portion of the pH sensor into a beaker containing the first buffer solution.
5. Allow the pH reading to stabilize. Allow the pH reading to stabilize. This may take several minutes, as the pH sensor may need to cool down to the buffer temperature. If you don't wait long enough you may get a slope error. Then note the temperature and find the buffer value at that temperature. Buffer values at various temperatures are located on the label of most buffer bottles.
6. Press the **CAL** key once. "bF 1" will display briefly, followed by the Numeric Display with digit flashing. If "bF2" displays, press the **CAL** key again.
7. **SCROLL** (▲) and **SHIFT** (Ô) to key in the buffer solution value, then **ENTER** it into memory.
8. Remove the sensor from the buffer, rinse and dry it.
9. Place the sensing portion of the pH sensor into a beaker containing the second buffer solution.
10. Allow the pH reading to stabilize. See note in step 5.
11. Press the **CAL** key once. "bF2" will display briefly, followed by the Numeric Display with digit flashing. If "bF 1" displays, press the **CAL** key again.
12. **SCROLL** (▲) and **SHIFT** (Ô) to key in the buffer solution value, then **ENTER** it into memory.
13. Press the **HOLD** key twice to remove the analyzer from hold.
14. For maximum accuracy, perform a process standardization after a buffer calibration (see Section 5.4). Also, you can track your electrode slope value after a buffer calibration to see how the electrode is aging (see Section 5.5).

5.4 pH Standardization. For maximum accuracy, the sensor should be standardized on-line or in a process grab sample after a buffer calibration to account for the sensor junction potential. Sensor standardization will not calculate the sensor's slope.

1. Take a grab sample which is as close to the sensor as possible. Write down the value the analyzer is reading at this time.

2. Using a calibrated pH instrument with automatic temperature compensation, determine the pH of the process or grab sample. The calibration is best performed at the process temperature. Write down this value. (If the sample pH is greater than about 6.5 and the lab sample is run at a substantially different temperature than the process, see note in section 4.7).
3. Before entering the standardized value, compare the value the analyzer is reading now to the value in Step 1. Add this change to the reference value obtained in Step 2. This accounts for the change while the grab sample is being measured.
4. Press the **pH** key once, then press the **SELECT** key. "5t8" will show followed by the Numeric Display with digit flashing.
5. **SCROLL** (▲) and **SHIFT** (Ô) to key in the corrected reference pH value determined in Step 3 then **ENTER** it into memory.

5.5 pH Glass Slope. The slope/efficiency of the glass electrode can be displayed or entered directly (if known) without buffer calibrating (A new electrode has a slope of about 59 mV/pH. As electrode ages the slope will decrease to about 47-49 mV/pH).

1. Press the **CAL/SLOPE** key twice, then the **SELECT** key once.
2. **SCROLL** (▲) and **SHIFT** (Ô) to key in the correct value then **ENTER** it into memory.

5.6 Sensor Maintenance. Before performing buffer checks or maintenance of the sensor, the analyzer should be placed in hold. This will place the current output and relays in the state set in the default setup (Section 4-8). Press the **HOLD** key twice. The hold flag will show to indicate the hold condition. Always calibrate after cleaning or repair of the pH sensor. (Refer to Sections 5.1.2 and 5.1.3.) After installing the sensor back in the process, press the **HOLD** key twice again to remove the analyzer from hold.

NOTE

To clean the electrode, rinse with distilled water or diluted acid/base, then gently dry with a clean tissue. The electrode should not be rubbed or abraded because this increases the electrostatic forces and thus the response time of the electrode, and it also rapidly ages the delicate electrode gel layer. If possible, increase the stirring or flow velocity past the electrode rather than rubbing or brushing it.

For any additional instructions, please refer to the appropriate sensor instruction manual.

SECTION 6.0

KEYBOARD SECURITY

6.1 KEYBOARD SECURITY. Display Mnemonic "C0d". Select this feature to display the user defined security code. Any three digit number may be used for this code. "000" will disable the security feature. This item is used to prevent accidental changes to the calibration and configuration of the analyzer. When activated, the analyzer will allow all read functions to read normally. If an attempt is made to change a value, "L0C" will display followed by the Numeric Display ready for the code to be entered. A proper code will unlock the analyzer and will return to the last function attempted. Any incorrect value will result in "bPd" briefly displaying. The analyzer will then return to numeric display and await the entry of the code. Once unlocked, the analyzer will allow access to all functions until the analyzer is either powered down or no keystrokes are made for a period of 2 minutes. If the code should be forgotten, pressing and holding the **ACCESS** key for 5 seconds will result in display of the code. Releasing the **ACCESS** key, then pressing **ENTER** will unlock the analyzer.

6.1.2 Keyboard Security (C0d).

1. Enter Set Mode by pressing **ACCESS** key twice.
2. **SCROLL** (▲) until "C0d" appears on the display.
3. **SELECT**.
4. **SCROLL** (▲) and **SHIFT** (Ô) to display the desired value, then **ENTER** it into memory.

NOTE

Entering "000" disables the keyboard security.

NOTE

Security feature will not activate until 2 minutes without keyboard activity or power is removed from the analyzer then restored.

SECTION 7.0

THEORY OF OPERATION

7.1 THEORY OF OPERATION. This section is a general description of how the Model 1054A pH operates. This section is for those users who desire a greater understanding of the analyzer's operation.

The measurement of the process' pH is accomplished by the use of two electrodes within the sensor. The glass electrode is pH sensitive and generates a high impedance millivolt potential directly proportional to the process pH. The reference electrode is a second half cell that completes the circuit

via a liquid junction. The high impedance signal is preamplified at the sensor to allow a stable noise-free signal that can be transmitted up to 1,000 feet.

The Model 1054A pH also measures the process temperature via a platinum 100 ohm RTD imbedded in the sensor. Advanced circuitry is used to eliminate errors due to changes in cable resistance. The analyzer uses this temperature measurement to compensate for changes in the sensor millivolt output caused by temperature change.

SECTION 8.0

DIAGNOSTICS AND TROUBLESHOOTING

8.1 DIAGNOSTICS. The Model 1054A pH has a diagnostic feature which automatically searches for fault conditions that would cause an error in the measured pH value. If such a condition occurs, the current output and relays will act as configured in Section 4-8 and the fault flag and display will flash. A fault code mnemonic will display at frequent intervals. If more than one fault condition exists, the display will sequence the faults at one second intervals. This will continue until the cause of the fault has been corrected. Display of fault mnemonics is suppressed when in Set Mode. Selecting the "SHD" item will display a history of the two most recent fault conditions unless "SHD" was cleared. Refer to Section 4.8C.

NOTE

If the analyzer is in hold and a fault occurs, the mnemonic "HLD" will display during the fault sequence.

8.1.1 Fault Mnemonics. Table 8-1 lists the fault mnemonics and describes the meaning of each.

8.1.2 Temperature Compensation. Table 8-2 is a ready reference of RTD resistance values at various temperatures. These are used for test and evaluation of the sensor.

NOTE

Ohmic values are read across the RTD element and are based on the manufacturer's stated values ($\pm 1\%$). Allow enough time for the RTD element to stabilize to the surrounding temperature.

TABLE 8-1. Fault Mnemonics

Display	Description	Display	Description
CAL	Warning to calibrate or clean sensor.	Ed	Electrode worn out, coated, or non-immersed.
CHS	ROM failure (check sum error) (bad ROM chip).	SEn	Sensor line error or wire length error.
CDP	Computer not operating properly.	SHL	Glass electrode cracked or broken.
EEP	EEPROM write error (bad EEPROM chip).	SLP	Slope variance error.
FAC	Factory calibration required.	tcH	High temperature compensation error.
i nH	Input shorted.	tcL	Low temperature or shorted RTD.
i nL	Sensor miswired.		

TABLE 8-2. RTD Resistance Values

Temperature	Resistance
0°C	100.00 ohms
10°C	103.90 ohms
20°C	107.79 ohms
30°C	111.67 ohms
40°C	115.54 ohms
50°C	119.40 ohms
60°C	123.24 ohms
70°C	127.07 ohms
80°C	130.89 ohms
90°C	134.70 ohms
100°C	138.50 ohms

8.2 TROUBLESHOOTING. The Model 1054A pH Analyzer is designed with state-of-the-art micro-processor circuitry, making troubleshooting simple and direct. Subassembly replacement, i.e. printed circuit board replacement, is all that is usually required.

8.2.1 Installation Failure. If failure does occur, complete the following steps:

1. Check for a fault flag. If a fault condition exists, refer to Table 8-1 for the fault mnemonic explanation.
2. Check wiring connections for proper installation.
3. Refer to Troubleshooting Table 8-3. The table is arranged with the most common problems listed first.

8.2.2 LCD/LED Display Test. Display Mnemonic "dE5". Selecting this option will activate all the display segments. This item is used if a faulty display is suspected. Refer to Figure 3-1 Keyboard Overlay.

1. Enter Set Mode by pressing **ACCESS** key twice.
2. **SCROLL** (▲) until "dE5" appears on the display.
3. **SELECT**.

8.2.3 Software Version. Display Mnemonic "uEr". Selection of this item will display the software revision level of the CPU. This number may be requested by factory service personnel if troubleshooting is required.

1. Enter Set Mode by pressing **ACCESS** key twice.
2. **SCROLL** (▲) until "uEr" appears on the display.
3. **SELECT**. (i.e., 2.0.6 displayed.)

8.2.4 Sensor Troubleshooting. In addition to the fault mnemonics that relate to a possible sensor problem (Tables 8-1 and 8-3), the analyzer can display the input in millivolts generated from the sensor. See Table 8-4 for how the millivolt input relates to pH. If the analyzer values do not agree within about 40 to 60 mV of those in the table, the analyzer has been incorrectly standardized for pH, the reference may be significantly poisoned, or some other significant problem exists. To read the millivolt input, go to 8.2.5.

For an additional diagnostics tool you can look at the "rE5" impedance value as described in Section 4.6.

8.2.5 Electrode Input. Display Mnemonic "Ei n". When selected, the analyzer displays the millivolt input from the sensor. The displayed value is not temperature corrected.

1. Press the **ACCESS** key twice. "5Ei" will briefly display followed by "Ei n". Not required if already in set menu.
2. **SELECT** this item to read the mV input.
3. Press the **pH** key to return to normal operation.

8.2.6 CPU Board Replacement. If there is a problem with the CPU board resulting in its replacement, specific procedures (included with the order) for calibrating the new board must be followed exactly or the microprocessor will be improperly programmed. Should this occur, it will be necessary to return the analyzer to the factory for reprogramming.

8.2.7 Power Board Replacement. If it becomes necessary to replace the power board, the CPU board will need to be recalibrated following specific procedures that are included with the power board. Failure to follow these procedures exactly will cause the microprocessor to be improperly programmed and require the return of the analyzer to the factory for reprogramming.

TABLE 8-4
Sensor Input to Analyzer Verses
pH at Four Temperatures*

pH	Input to Analyzer in Millivolts			
	15°C (59°F)	25°C (77°F)	50°C (122°F)	80°C (176°F)
0	396	410	444	486
1	340	351	381	416
2	283	293	317	347
3	226	234	254	277
4	170	176	190	208
5	113.2	117.1	127.0	138.7
6	56.6	58.6	63.5	69.4
7	0	0	0	0
8	- 56.6	- 58.6	- 63.5	- 69.4
9	- 113.2	- 117.1	- 127.0	- 138.7
10	- 170	- 176	- 190	- 208
11	- 226	- 234	- 254	- 277
12	- 283	- 293	- 317	- 347
13	- 340	- 351	- 381	- 416
14	- 396	- 410	- 444	- 486

* These values do not apply for non-glass electrodes.

TABLE 8-3. Troubleshooting Guide

SYMPTOM	PROBLEM	ACTION
Fault code "CAL".	1. Warning to calibrate sensor with buffers. Electrode is aging or coated. 2. Electrode is not in solution.	1. Calibrate with buffers (First clean if necessary). 2. Immerse electrode in solution.
Fault code "5HE". pH is a constant value in any buffer. "rE5" value less than 70% of normal.	1. Glass electrode broken.	1. Replace electrode.
Fault code "QI d".	1. Electrode is worn out or coated. If electrode is worn out, "SLP" will also be low and the electrode sluggish. 2. Electrode is not in solution.	1. Replace or clean electrode as soon as possible. 2. Immerse electrode in solution.
"Ei n" increasingly greater or less than zero mV at 7pH, with increased poisoning.	1. Reference becoming poisoned.	1. Replace reference or sensor. 2. Request a special triple junction sensor if necessary.
pH value locks up (no change of solutions in buffers).	1. Glass electrode cracked. 2. Coated glass electrode. 3. Junction plugged.	1. Replace glass electrode. 2. Clean glass electrode. 3. Replace junction.
1054A pH value not the same as grab sample of process.	1. Grab sample incorrect. 2. Unclear what is correct. 3. Analyzer out of calibration.	1. Re-evaluate sample technique and equipment. 2. Test with buffer solution. 3. Recalibrate per start-up and calibration section.
Fault code "EcH"/"EcL".	1. Miswired or temperature out of range. 2. Open or shorted RTD.	1. Check wiring between the sensor and analyzer. Check process temp. 2. Replace RTD with new one.
Fault code "i nH" or "i nL".	1. Open wire from preamplifier. 2. Bad preamplifier. 3. Defective CPU.	1. Check wiring between preamplifier and analyzer. 2. Replace preamplifier. 3. Replace CPU PCB.
Fault code "SLP".	1. Defective electrode. 2. Improper buffer calibration. 3. Coated electrode. 4. Plugged liquid junction.	1. Replace electrode. 2. Recheck buffer accuracies. 3. Clean or replace electrode. 4. Replace junction.
Fault code "SEn".	1. Open wire between sensor and analyzer. 2. Cable length has been exceeded. Maximum length: 1000 ft. after preamp.	1. Repair wire. 2. Check wiring.
Fault code "EEP".	1. Defective EEPROM.	1. Replace CPU PCB.
Fault code "CH5".	1. Defective CPU.	1. Replace CPU PCB.
No alarm relay closure.	1. Defective power board. 2. Defective CPU.	1. Replace power PCB. 2. Replace CPU PCB.
No output current.	1. Defective output board. 2. Miswire.	1. Replace power PCB. 2. Check for short.
Low output current.	1. Circuit loading with excessive resistance on output.	1. Consult output loading limits 1054A pH specifications (600 ohms max load).

TABLE 8-5. Replacement Parts and Accessories

P/N	DESCRIPTION
22966-00	PCB, LCD Digital Display
23025-01	Panel Mounting Kit
23053-00	Mounting Bracket, 2-inch Pipe
23054-01	Mounting Bracket, Wall, with Junction box
23056-02	PCB, 115V Power Supply
23056-03	PCB, 230V Power Supply
23245-01	PCB, LED Digital Display
23268-01	Heater Kit, 115V, Wall Mounting Enclosure
23268-02	Heater Kit, 230V, Wall Mounting Enclosure
23316-00	PCB, Motherboard
23317-00	Keyboard Overlay, pH, LCD Version
23317-01	Keyboard Overlay, pH, LED Version
23363-00	Preamplifier, Pt 100 (Group 1 only)
23508-00	Preamplifier, Pt 100 (Group 11 only)
23532-00	PCB, CPU, pH, with electrode diagnostics
32934-00	Enclosure
32936-00	Enclosure, Rear Cover
32937-00	Gasket, Rear Cover
9100153	Fuse, 0.125, 2AG, 250V
9100157	Fuse, 0.1A, 3AG, 250V, Slo Blo

TABLE 8-6. Ordering Information

The **Model 1054A Microprocessor Analyzer** is housed in a NEMA 4X weatherproof, corrosion-resistant housing suitable for panel, pipe or wall mounting. The analyzer operates on 115 VAC, 60 Hz unless otherwise specified. Standard features include an LCD digital display, continuous self diagnostics, isolated current output, dual alarms, and automatic temperature compensation.

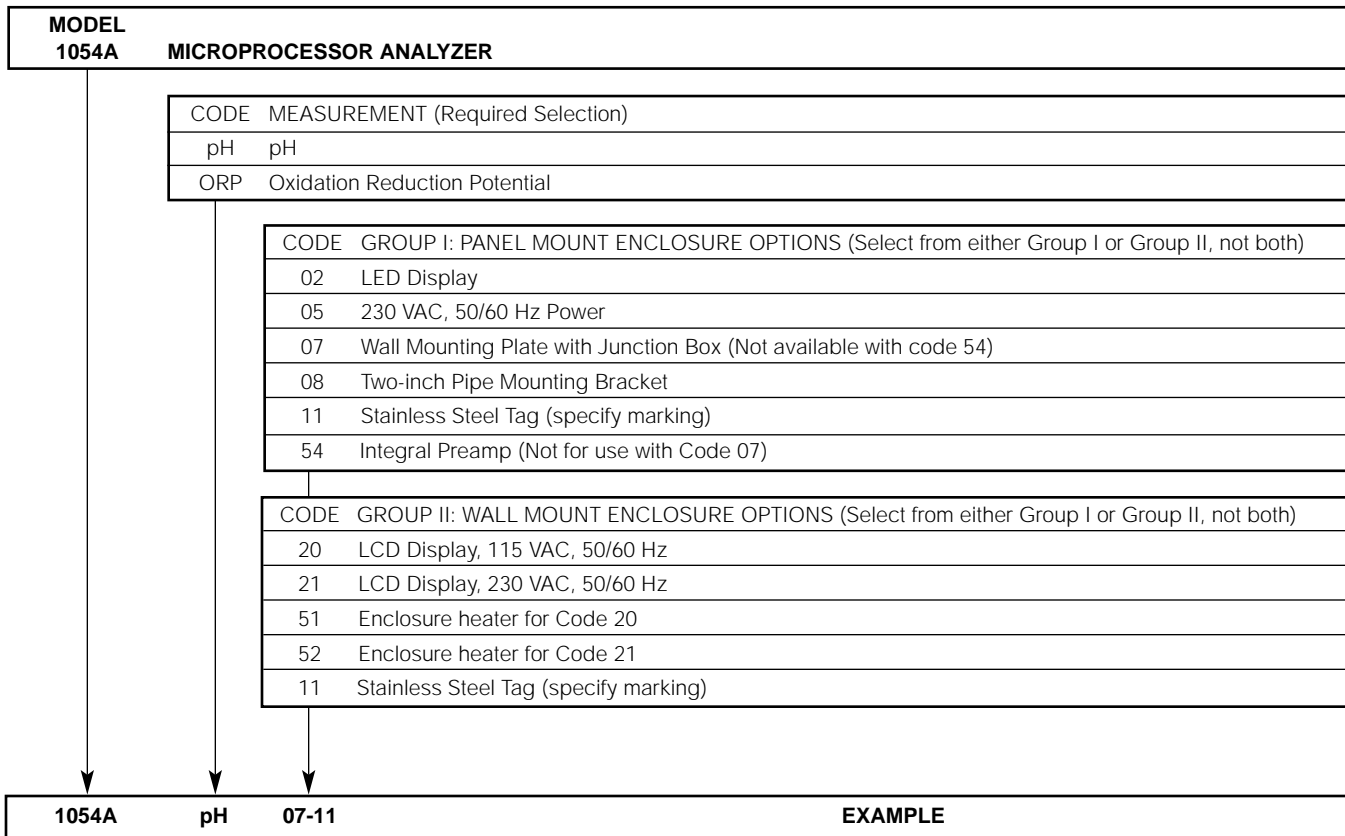

NOTE: SELECT OPTIONS FROM GROUP I OR GROUP II, NOT BOTH.

SECTION 9.0 RETURN OF MATERIALS

9.1 GENERAL. To expedite the repair and return of instruments, proper communication between the customer and the factory is important. A return material authorization number is required. Call 949 863-1181. The "Return of Materials Request" form is provided for you to copy and use in case the situation arises. The accuracy and completeness of this form will affect the processing time of your materials.

9.2 WARRANTY REPAIR. The following is the procedure for returning products still under warranty.

1. Contact the factory for authorization.
2. Complete a copy of the "Return of Materials Request" form as completely and accurately as possible.
3. To verify warranty, supply the factory sales order number or the original purchase order number. In the case of individual parts or sub-assemblies, the serial number on the mother unit must be supplied.
4. Carefully package the materials and enclose your "Letter of Transmittal" and the completed copy of the "Return of Materials Request" form. If possible, pack the materials in the same manner as it was received.

IMPORTANT

Please see second section of "Return of Materials Request Form". Compliance to the OSHA requirements is mandatory for the safety of all personnel. MSDS forms and a certification that the instruments have been disinfected or detoxified are required.

5. Send the package prepaid to:

Rosemount Analytical Inc.
2400 Barranca Parkway
Irvine, CA 92606

Attn: Factory Repair

Mark the package:

Returned for Repair RMA No. _____

Model No. _____

9.3 NON WARRANTY REPAIR.

1. Contact the factory for authorization.
2. Fill out a copy of the "Return of Materials Request" form as completely and accurately as possible.
3. Include a purchase order number and make sure to include the name and telephone number of the right individual to be contacted should additional information be needed.
4. Do Steps 4 and 5 of Section 9.2.

NOTE

Consult the factory for additional information regarding service or repair.



The right people, the right answers, right now.

Immediate, Reliable Analytical Support

Now there's a way to quickly get the right answers for your liquid analytical instrumentation questions: the Analytical Customer Support Center.

Our staff of trained professionals are ready to provide the information you need. If you are placing an order, verifying delivery, requesting application information, or just want to contact a Rosemount Analytical representative, a toll-free call to 1-800-854-8257 will provide you with the right people, the right answers, right now.

A Worldwide Network of Sales and Service

The Rosemount customer sales and service organization comprises a network of fully equipped support centers strategically located throughout the world. From many of these locations, the Rosemount Group provides support, distribution of finished products, repair facilities, and training for our customers.

U.S. Field Service

Field Watch Response Center
1-800-654-7768

International

ARGENTINA

Emerson Argentina
Buenos Aires
54 1 780311,
795-9338

AUSTRALIA

Fisher-Rosemount
Pty. Ltd.
Bayswater, Victoria
(61)(39)721-0200

AUSTRIA

Fisher-Rosemount - AG
Neudorf
(43)(2236)607

BELGIUM

Fisher-Rosemount
N.V./S.A.
Diegem
(32)(2)716-77-11

BRAZIL

Fisher-Rosemount do
Brasil Industria e
Comercio Ltda.
Sorocada
(55)(11)228 3788

CANADA

Rosemount Instruments
Ltd.
Calgary
(800) 268-1151

CHINA

Fisher-Rosemount
Pudong, Shanghai
(86)(215)899-4415

CROATIA

Fisher-Rosemount
Croatia
Zagreb
(385)(1)305 071

CZECH REPUBLIC

Fisher-Rosemount
Praha
(420)(2)81002666-7

DENMARK

Fisher-Rosemount A/S
Alleroed
(45)48-17-03-33

ENGLAND

Fisher-Rosemount
Limited
Bognor Regis
(44)(1243)863-121

FINLAND

Oy Valment-Rosemount
AG
ESPOO
(358)(9)549-541

FRANCE

Fisher-Rosemount S.A.
Lyon
(33)(7)215-98-00

GERMANY

Fisher-Rosemount
GmbH & Co.
D-63549 Hasselroth
(49)(6055)884-0

HUNGARY

Fisher-Rosemount
Budapest
(36)(1)4624001

INDIA

Fisher-Rosemount
(India) Ltd.
New Bombay
(91)(22)762-9191/9200

ITALY

Fisher-Rosemount
Italia s.r.l.
Milan
(11)(39)(39)27021

JAPAN

Fisher-Rosemount Japan
Co., Ltd.
Tokyo
(81)(3)5403-8529

KOREA

Fisher-Rosemount
Korea Ltd.
Seoul
(82)(2)515-2321

MIDDLE EAST

Fisher-Rosemount
Middle-East Dubai,
United Arab Emirates
(971)(4)835235

MALAYSIA

Rosemount Instruments
SDN BHD
Kuala Lumpur
(60)(3)244-5688

MEXICO

Fisher-Rosemount S.A.
de C.V.
Tlalnepantla
(011)(525)728-0885

NEW ZEALAND

Fisher-Rosemount
Auckland
(64)(9)444-1646

NORWAY

Fisher-Rosemount A/S
Porsgrunn
(47)35-55-5600

POLAND

Fisher-Rosemount
Warszawa
(48)(22)857 3856/
647 3865

PORTUGAL

Fisher-Rosemount
Portugal Instrumentos
Limitada
Alfragide
(351)(1)472 88 50

PUERTO RICO

Fisher-Rosemount Inc.
Guaynabo
(787)782-9955, 9956,
or 9957

ROMANIA

Fisher-Rosemount
Bucharest
40 1230 4149/50/59

RUSSIA

Fisher-Rosemount
Moscow
7095 245 86 86

SINGAPORE

Fisher-Rosemount
Singapore
Pte, Ltd
(65)777-8211

SLOVAK REPUBLIC

Fisher-Rosemount scr
Bratislava
42 17 761 973

SPAIN

Fisher-Rosemount S.A.
Madrid
(34)(1)358-91-41

SWEDEN

Fisher-Rosemount AB
Karlstad
(46)(54)19-0090

SWITZERLAND

Fisher-Rosemount AG
Baar
(41)(41)768 62 60

THE NETHERLANDS

Fisher-Rosemount BV
Rijswijk
(31)(70)413-6542

TURKEY

Fisher-Rosemount
Proses Kontrol Ltd. Sri
Istanbul
(90)(216)49 240 42-46

ROSEMOUNT® ANALYTICAL
FISHER-ROSEMOUNT™ Managing The Process Better.™

RETURN OF MATERIALS REQUEST

•IMPORTANT!
This form must be completed to ensure expedient factory service.

C U S T O M E R	FROM: _____ _____ _____	RETURN _____ _____ _____	BILL TO: _____ _____ _____												
N O T I C E T O S U B M I T T E R	<p>CUSTOMER/USER MUST SUBMIT MATERIAL SAFETY SHEET (MSDS) OR COMPLETE STREAM COMPOSITION, AND/OR LETTER CERTIFYING THE MATERIALS HAVE BEEN DISINFECTED AND/OR DETOXIFIED WHEN RETURNING ANY PRODUCT, SAMPLE OR MATERIAL THAT HAVE BEEN EXPOSED TO OR USED IN AN ENVIRONMENT OR PROCESS THAT CONTAINS A HAZARDOUS MATERIAL ANY OF THE ABOVE THAT IS SUBMITTED TO ROSEMOUNT ANALYTICAL WITHOUT THE MSDS WILL BE RETURNED TO SENDER C.O.D. FOR THE SAFETY AND HEALTH OF OUR EMPLOYEES. WE THANK YOU IN ADVANCE FOR COMPLIANCE TO THIS SUBJECT.</p>														
<p>SENSOR OR CIRCUIT BOARD ONLY: (Please reference where from in MODEL / SER. NO. Column)</p> <table style="width:100%; border-collapse: collapse;"> <tr> <td style="width: 33%;">1. PART NO. _____</td> <td style="width: 33%;">1. MODEL _____</td> <td style="width: 33%;">1. SER. NO. _____</td> </tr> <tr> <td>2. PART NO. _____</td> <td>2. MODEL _____</td> <td>2. SER. NO. _____</td> </tr> <tr> <td>3. PART NO. _____</td> <td>3. MODEL _____</td> <td>3. SER. NO. _____</td> </tr> <tr> <td>4. PART NO. _____</td> <td>4. MODEL _____</td> <td>4. SER. NO. _____</td> </tr> </table>				1. PART NO. _____	1. MODEL _____	1. SER. NO. _____	2. PART NO. _____	2. MODEL _____	2. SER. NO. _____	3. PART NO. _____	3. MODEL _____	3. SER. NO. _____	4. PART NO. _____	4. MODEL _____	4. SER. NO. _____
1. PART NO. _____	1. MODEL _____	1. SER. NO. _____													
2. PART NO. _____	2. MODEL _____	2. SER. NO. _____													
3. PART NO. _____	3. MODEL _____	3. SER. NO. _____													
4. PART NO. _____	4. MODEL _____	4. SER. NO. _____													
R E A S O N F O R R E T U R N	<p>PLEASE CHECK ONE:</p> <table style="width:100%; border-collapse: collapse;"> <tr> <td style="width: 50%;"><input type="checkbox"/> REPAIR AND CALIBRATE</td> <td style="width: 50%;"><input type="checkbox"/> DEMO EQUIPMENT NO. _____</td> </tr> <tr> <td><input type="checkbox"/> EVALUATION</td> <td><input type="checkbox"/> OTHER (EXPLAIN) _____</td> </tr> <tr> <td><input type="checkbox"/> REPLACEMENT REQUIRED? <input type="checkbox"/> YES <input type="checkbox"/> NO</td> <td>_____</td> </tr> </table> <p>DESCRIPTION OF MALFUNCTION: _____ _____ _____</p>			<input type="checkbox"/> REPAIR AND CALIBRATE	<input type="checkbox"/> DEMO EQUIPMENT NO. _____	<input type="checkbox"/> EVALUATION	<input type="checkbox"/> OTHER (EXPLAIN) _____	<input type="checkbox"/> REPLACEMENT REQUIRED? <input type="checkbox"/> YES <input type="checkbox"/> NO	_____						
<input type="checkbox"/> REPAIR AND CALIBRATE	<input type="checkbox"/> DEMO EQUIPMENT NO. _____														
<input type="checkbox"/> EVALUATION	<input type="checkbox"/> OTHER (EXPLAIN) _____														
<input type="checkbox"/> REPLACEMENT REQUIRED? <input type="checkbox"/> YES <input type="checkbox"/> NO	_____														
R E P A I R S T A T U S	<p>WARRANTY REPAIR REQUESTED:</p> <table style="width:100%; border-collapse: collapse;"> <tr> <td style="width: 50%;"><input type="checkbox"/> YES-REFERENCE ORIGINAL ROSEMOUNT ANALYTICAL ORDER NO. _____</td> <td style="width: 50%;">CUSTOMER PURCHASE ORDER NO. _____</td> </tr> <tr> <td colspan="2"><input type="checkbox"/> NO-PROCEED WITH REPAIRS-INVOICE AGAINST P.O. NO. _____</td> </tr> <tr> <td colspan="2"><input type="checkbox"/> NO-CONTACT WITH ESTIMATE OF REPAIR CHARGES: LETTER <input type="checkbox"/> _____</td> </tr> <tr> <td colspan="2">PHONE <input type="checkbox"/> _____</td> </tr> </table>			<input type="checkbox"/> YES-REFERENCE ORIGINAL ROSEMOUNT ANALYTICAL ORDER NO. _____	CUSTOMER PURCHASE ORDER NO. _____	<input type="checkbox"/> NO-PROCEED WITH REPAIRS-INVOICE AGAINST P.O. NO. _____		<input type="checkbox"/> NO-CONTACT WITH ESTIMATE OF REPAIR CHARGES: LETTER <input type="checkbox"/> _____		PHONE <input type="checkbox"/> _____					
<input type="checkbox"/> YES-REFERENCE ORIGINAL ROSEMOUNT ANALYTICAL ORDER NO. _____	CUSTOMER PURCHASE ORDER NO. _____														
<input type="checkbox"/> NO-PROCEED WITH REPAIRS-INVOICE AGAINST P.O. NO. _____															
<input type="checkbox"/> NO-CONTACT WITH ESTIMATE OF REPAIR CHARGES: LETTER <input type="checkbox"/> _____															
PHONE <input type="checkbox"/> _____															
<p>NAME _____ PHONE _____</p> <p>ADDRESS _____</p> <p>_____ ZIP _____</p>															
<p>RETURN AUTHORITY FOR CREDIT ADJUSTMENT [Please check appropriate box(s)]</p> <table style="width:100%; border-collapse: collapse;"> <tr> <td style="width: 50%;"><input type="checkbox"/> WRONG PART RECEIVED</td> <td style="width: 50%;"><input type="checkbox"/> REPLACEMENT RECEIVED</td> </tr> <tr> <td><input type="checkbox"/> DUPLICATE SHIPMENT</td> <td>REFERENCE ROSEMOUNT ANALYTICAL SALES ORDER NO. _____</td> </tr> <tr> <td><input type="checkbox"/> RETURN FOR CREDIT</td> <td>RETURN AUTHORIZED BY: _____</td> </tr> <tr> <td colspan="2">WARRANTY DEFECT _____</td> </tr> </table>				<input type="checkbox"/> WRONG PART RECEIVED	<input type="checkbox"/> REPLACEMENT RECEIVED	<input type="checkbox"/> DUPLICATE SHIPMENT	REFERENCE ROSEMOUNT ANALYTICAL SALES ORDER NO. _____	<input type="checkbox"/> RETURN FOR CREDIT	RETURN AUTHORIZED BY: _____	WARRANTY DEFECT _____					
<input type="checkbox"/> WRONG PART RECEIVED	<input type="checkbox"/> REPLACEMENT RECEIVED														
<input type="checkbox"/> DUPLICATE SHIPMENT	REFERENCE ROSEMOUNT ANALYTICAL SALES ORDER NO. _____														
<input type="checkbox"/> RETURN FOR CREDIT	RETURN AUTHORIZED BY: _____														
WARRANTY DEFECT _____															

24-6047

Rosemount Analytical Inc.
Uniloc Division
2400 Barranca Parkway
Irvine, CA 92606 USA
Tel: 1-800-854-8257
Fax: (949)-474-7250

ROSEMOUNT® ANALYTICAL
FISHER-ROSEMOUNT™ Managing The Process Better.™

WARRANTY

Goods and part(s) (excluding consumables) manufactured by Seller are warranted to be free from defects in workmanship and material under normal use and service for a period of twelve (12) months from the date of shipment by Seller. Consumables, pH electrodes, membranes, liquid junctions, electrolyte, O-rings, etc. are warranted to be free from defects in workmanship and material under normal use and service for a period of ninety (90) days from date of shipment by Seller. Goods, part(s) and consumables proven by Seller to be defective in workmanship and / or material shall be replaced or repaired, free of charge, F.O.B. Seller's factory provided that the goods, parts(s), or consumables are returned to Seller's designated factory, transportation charges prepaid, within the twelve (12) month period of warranty in the case of goods and part(s), and in the case of consumables, within the ninety (90) day period of warranty. This warranty shall be in effect for replacement or repaired goods, part(s) and consumables for the remaining portion of the period of the twelve (12) month warranty in the case of goods and part(s) and the remaining portion of the ninety (90) day warranty in the case of consumables. A defect in goods, part(s) and consumables of the commercial unit shall not operate to condemn such commercial unit when such goods, parts(s) or consumables are capable of being renewed, repaired or replaced.

The Seller shall not be liable to the Buyer, or to any other person, for the loss or damage, directly or indirectly, arising from the use of the equipment or goods, from breach of any warranty or from any other cause. All other warranties, expressed or implied are hereby excluded.

IN CONSIDERATION OF THE STATED PURCHASE PRICE OF THE GOODS, SELLER GRANTS ONLY THE ABOVE STATED EXPRESS WARRANTY. NO OTHER WARRANTIES ARE GRANTED INCLUDING, BUT NOT LIMITED TO, EXPRESS AND IMPLIED WARRANTIES OF MERCHANTABILITY AND FITNESS FOR A PARTICULAR PURPOSE.

RETURN OF MATERIAL

Material returned for repair, whether in or out of warranty, should be shipped prepaid to:

**Rosemount Analytical Inc.
Uniloc Division
2400 Barranca Parkway
Irvine, CA 92606**

The shipping container should be marked:

Return for Repair
Model _____

The returned material should be accompanied by a letter of transmittal which should include the following information (make a copy of the "Return of Materials Request" found on the last page of the Manual and provide the following thereon):

1. Location type of service, and length of time of service of the device.
2. Description of the faulty operation of the device and the circumstances of the failure.
3. Name and telephone number of the person to contact if there are questions about the returned material.
4. Statement as to whether warranty or non-warranty service is requested.
5. Complete shipping instructions for return of the material.

Adherence to these procedures will expedite handling of the returned material and will prevent unnecessary additional charges for inspection and testing to determine the problem with the device.

If the material is returned for out-of-warranty repairs, a purchase order for repairs should be enclosed.

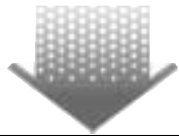

*The right people,
the right answers,
right now.*

UNILOC DIVISION
CUSTOMER SUPPORT CENTER
1-800-854-8257

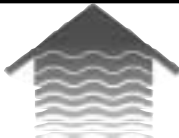

Rosemount Analytical Inc.
Uniloc Division
2400 Barranca Parkway
Irvine, CA 92606 USA
Tel: (949) 863-1181
<http://www.RAuniloc.com>

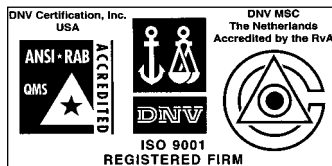

*ON-LINE ORDERING NOW
AVAILABLE ON OUR WEB SITE*
<http://www.RAuniloc.com>

Credit Cards for U.S. Purchases Only.

