

# UNIVERSAL MOTION INTERFACE (UMI) ACCESSORY

This user guide describes how to use the UMI-7764, UMI-4A, UMI-Flex6, and UMI-Flex4 accessories.

## Contents

---

Introduction .....	2
What You Need to Get Started .....	2
UMI-7764.....	4
Motion I/O Terminal Block .....	5
Amplifier/Driver Terminal Block.....	5
Encoder Terminal Block.....	6
Limit Switch Terminal Block .....	8
Analog Input Terminal Block.....	9
Breakpoint Output/Trigger Input Terminal Block.....	9
Shutdown/Inhibit All Terminal Block .....	10
Power Input Terminal Block.....	10
UMI-7764 Specifications .....	11
UMI-4A.....	13
Amplifier/Driver Terminal Block.....	13
Encoder Terminal Block.....	15
Limit Switch Terminal Block .....	16
Digital I/O Terminal Blocks .....	17
Power Input Terminal Block.....	18
UMI-4A Specifications .....	19
UMI-Flex6 .....	21
Amplifier/Driver Terminal Block.....	21
Encoder Terminal Block.....	22
Limit Switch Terminal Block .....	24
Analog Input Terminal Blocks .....	25
Breakpoint Output Terminal Block .....	26
Power Input Terminal Block.....	26
UMI-Flex6 Specifications.....	27
UMI-Flex4 .....	28
Amplifier/Driver Terminal Block.....	28
Encoder Terminal Block.....	30
Limit Switch Terminal Block .....	32
Analog Input Terminal Block.....	32
Breakpoint Output Terminal Block .....	33
Power Input Terminal Block.....	33
UMI-Flex4 Specifications.....	34

# Introduction

---

The UMI products are connectivity accessories you can use with your motion control boards for up to four or six axes of simultaneous or independent control. Ideally suited to industrial and laboratory applications, UMI accessories connect power supplies, servo amplifiers or stepper drivers, motors, encoders, and limit switches to National Instruments plug-in motion control boards.

A UMI accessory simplifies field wiring with separate encoder, limit switch, and amplifier/driver terminal blocks per axis. All terminal blocks are industry standard and do not require any special tools for wire installation. The UMI accessory connects to the motion controller via a single interface cable. The UMI accessory has a host bus monitor power interlock that automatically disables the amplifiers if the host computer is shut down or the interface cable is disconnected.

The UMI-4A and UMI-Flex4 come with an integrated DIN-rail mounting base. The UMI-Flex6 is encased in metal and comes with attached rubber feet for desktop use; a DIN-rail mounting kit is available separately. The UMI-7764 is encased in a metal box with a hinged lid and comes with attached rubber feet for desktop use.



**Note** Throughout this document, overlined text indicates that a signal is active-low.

## What You Need to Get Started

---

To set up and use your UMI accessory, you will need the following items:

- ❑ One of the following UMI accessories:
  - UMI-7764
  - UMI-4A
  - UMI-Flex6
  - UMI-Flex4
- ❑ *Universal Motion Interface (UMI) Accessory User Guide*

- One of the following National Instruments cables:

<b>UMI Accessory</b>	<b>Cable</b>	<b>Motion Controller</b>
UMI-7764	SH68-C68-S	All 7344 controllers, PCI-7324, PCI-7314
UMI-7764	SH68-68-S	PXI-7324, PXI-7314
UMI-4A	SH50-50, NB1	50-pin ValueMotion controllers
UMI-Flex6, UMI-Flex4	SH-Flex-100	100-pin FlexMotion controllers

- +5 V power supply
- (Optional) Auxiliary power supply (UMI-4A only)
- (Optional) ISO power supply (UMI-Flex4 and UMI-Flex6 only)

Detailed specifications for each of the UMI accessories are in the *Specifications* section for each device.

# UMI-7764

This section describes the UMI-7764 terminal block. Refer to Figure 1 to help you locate the different parts of the UMI-7764 accessory.

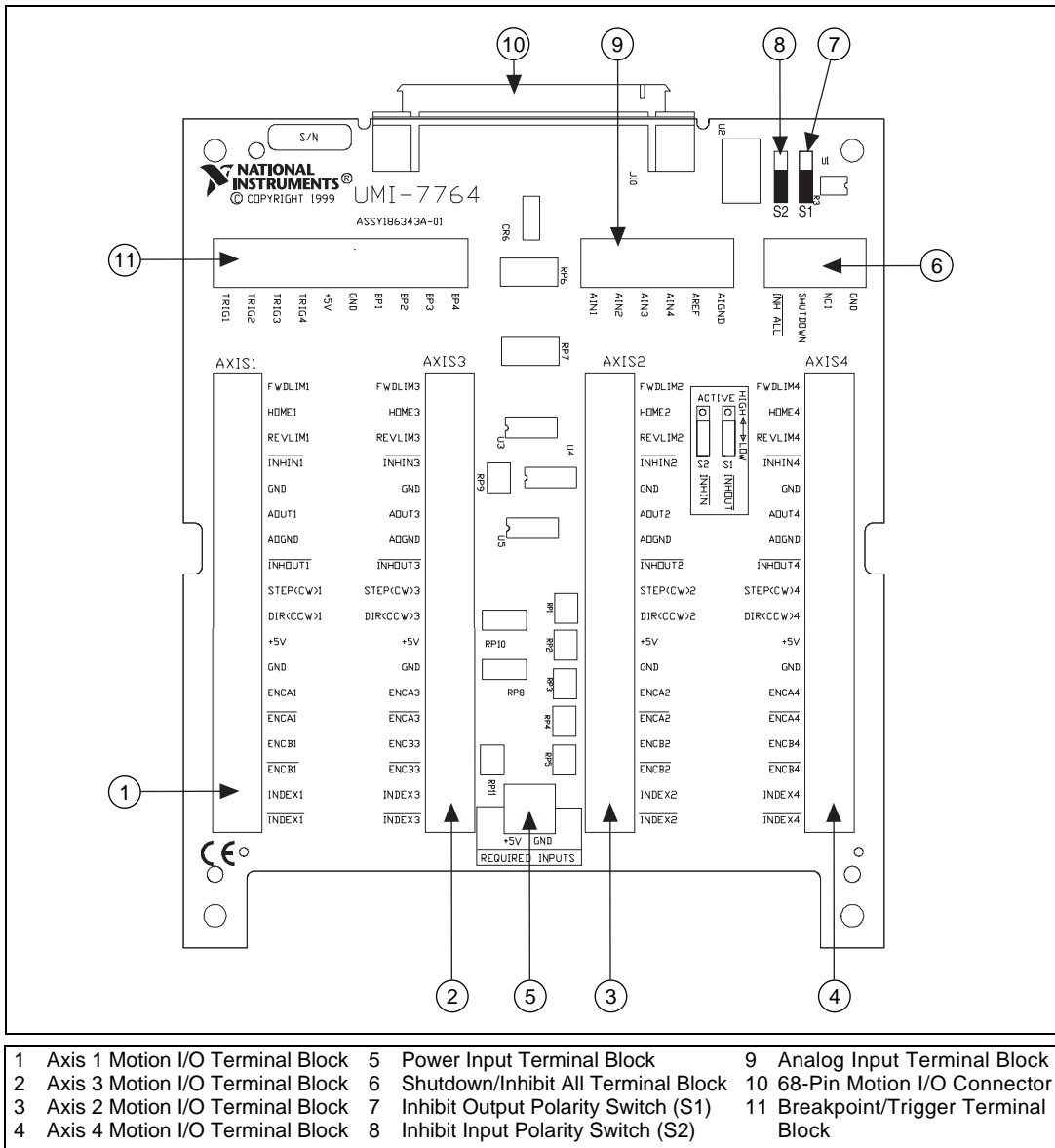

**Figure 1.** UMI-7764 Parts Locator Diagram

## Motion I/O Terminal Block

Each axis connected to the UMI-7764 has a motion I/O terminal block to which the following signals are wired:

- Amplifier/driver connections
- Encoder connections
- Limit switch connections
- Distributed power connections

Figure 2 shows which portions of the terminal block are used for different functionality.

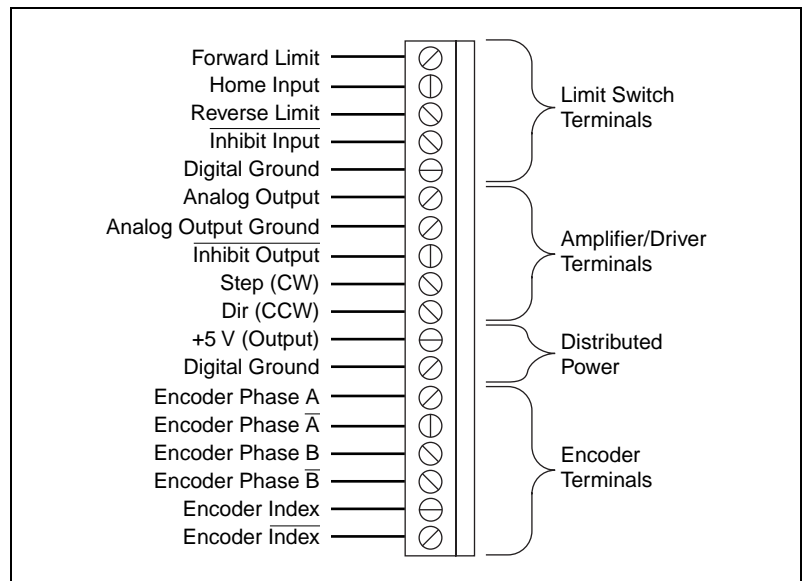

**Figure 2.** UMI-7764 Motion I/O Terminal Block

## Amplifier/Driver Terminal Block

Each UMI-7764 axis motion I/O terminal block has five terminals for amplifier/driver connections. Refer to Figures 1 and 2 to locate the amplifier/driver terminals on your UMI-7764 accessory. Figure 3 shows the UMI-7764 amplifier/driver terminal block pin assignment for the servo/stepper axes.

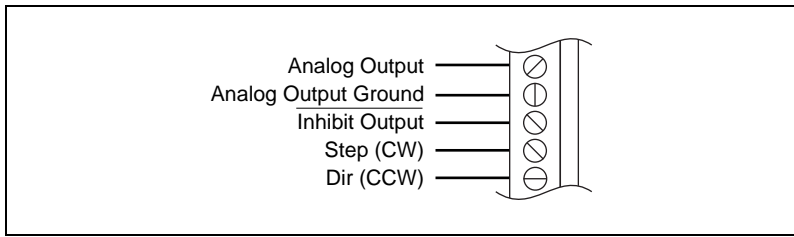

**Figure 3.** UMI-7764 Axes Amplifier/Driver Terminal Block Pin Assignments

The Analog Output signals are used as command outputs to a servo amplifier or as general-purpose voltage outputs. The Step and Dir signals are used as command outputs to a stepper driver.

The Inhibit Output signals are used to disable the amplifier/driver for that axis. The UMI combines the host bus interlock circuit, the Inhibit All signal, the per axis Inhibit Input signals, and the per axis controller Inhibit Output to create the per axis Inhibit Output signal. The host bus interlock monitors the +5 V pin from the motion controller to verify that the controller is powered and properly connected to the UMI. If the host bus interlock detects a problem, if the Inhibit All signal is asserted, or if the Inhibit Input signal or the controller Inhibit Output signal for that axis is asserted, the Inhibit Output from the UMI-7764 for that axis is asserted.

You can configure the axis Inhibit Out signal as active-low or active-high output using switch S1. Setting S1 to the bottom configures the signal as active-low; setting S1 to the top configures the signal as active-high.



**Note** You must configure the controller’s Inhibit Output signals as active-low for proper operation of the inhibit circuitry.

## Encoder Terminal Block

Each UMI-7764 axis motion I/O terminal block has six terminals for incremental encoder connections. The UMI-7764 accepts either single-ended TTL or differential line driver inputs. You can connect open-collector encoders to the UMI-7764 accessory by installing a 2.2 k $\Omega$  pull-up resistor to +5 V.



**Note** Encoders with line driver outputs are recommended for all applications and must be used if the encoder cable length is greater than 10 feet.

Power for the encoders is internally routed from the power input terminal block and is available on the +5 V terminal on each axis motion I/O terminal block. You must supply a +5 V source to the power input terminal block for proper operation. Refer to Figures 1 and 2 to help you locate the encoder terminals on your UMI-7764 accessory. Figure 4 shows the wiring for a differential encoder.



**Note** The dotted loop indicates a shielded cable.

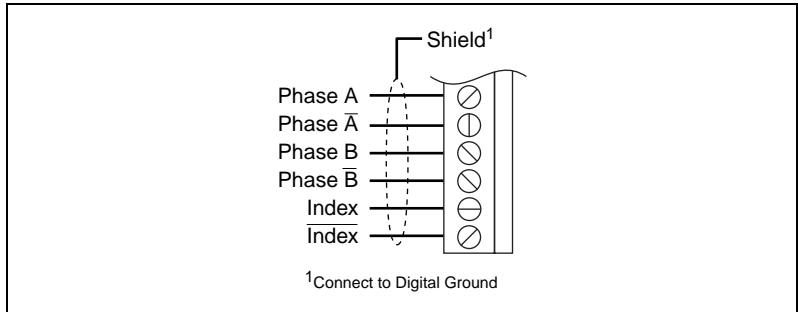

**Figure 4.** Differential Encoder Wiring

Figure 5 shows the wiring for the single-ended encoder.

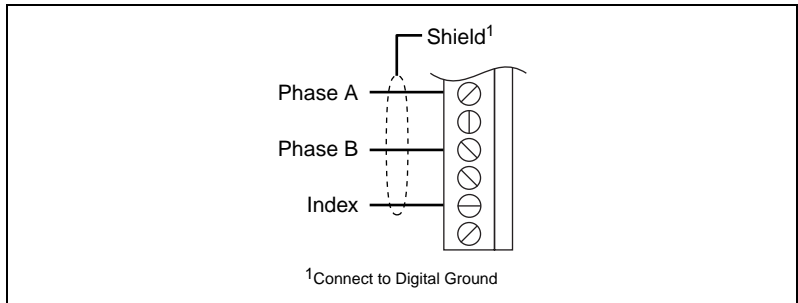

**Figure 5.** Single-Ended Encoder Wiring

The UMI-7764 accessory allows for differential inputs for Phase A, Phase B, and Index signals. You can easily accommodate encoders with phase relationships different from Figure 6 by swapping the signals as required by the specific application. The Index pulse must occur when both Phase A and Phase B signals are logic low as shown in Figure 6. Servo and closed-loop stepper applications require encoder feedback and consistent directional polarity between the motor and encoder for stable operation. The UMI-7764 uses the following standards for motor direction:

- Positive = forward = Clockwise (CW) facing motor shaft
- Negative = reverse = Counter-clockwise (CCW) facing motor shaft

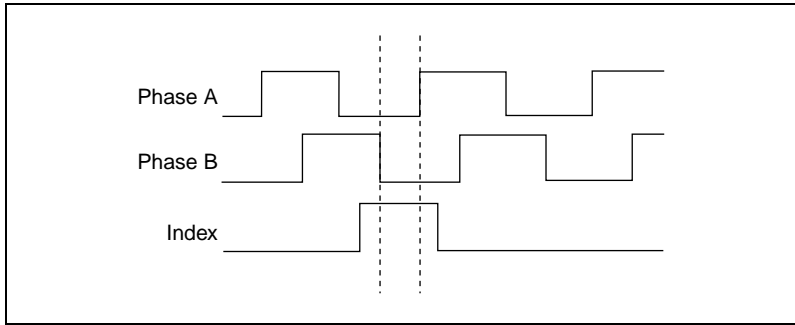

**Figure 6.** Encoder Signal Phasing—CW Rotation

The encoder inputs are filtered by both analog and digital noise filters. You must use cables with twisted pairs and an overall shield for improved noise immunity. When connecting the encoder to the UMI-7764, you should use at least 24-AWG wire.



**Caution** Using an unshielded cable allows noise to corrupt the encoder signals, which results in lost counts, reduced accuracy, and other erroneous encoder and controller operations.

## Limit Switch Terminal Block

Each UMI-7764 axis motion I/O terminal block has five terminals for Forward and Reverse Limit and Home Input switch connections. Refer to Figures 1 and 2 to help you locate the limit switch terminals on your UMI-7764 accessory. See Figure 7 for the UMI-7764 limit switch terminal block pinout.

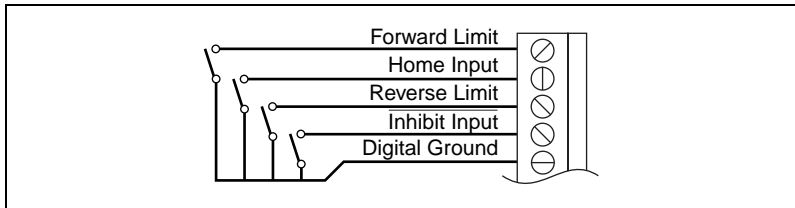
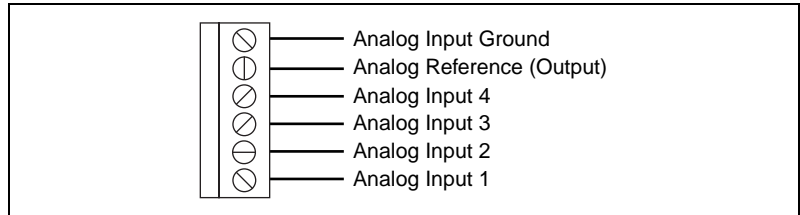

**Figure 7.** UMI-7764 Limit Switch Terminal Block Pin Assignment

You can configure the axis Inhibit Input signals as active-low or active-high inputs using switch S2. Setting S2 to the bottom configures the signal as active-low; setting S2 to the top configures the signal as active-high. The Inhibit Input signals include a 3.3 k $\Omega$  pull-up resistor on their inputs.

## Analog Input Terminal Block

For analog input wiring, the UMI-7764 has a 6-position terminal block, which provides access to the four analog input channels on your motion controller. Refer to Figure 1 to help you locate the analog input terminal block on your UMI-7764 accessory. See Figure 8 for analog input terminal block pinout information.



**Figure 8.** UMI-7764 Analog Input Terminal Block Pin Assignments

## Breakpoint Output/Trigger Input Terminal Block

For breakpoint output and trigger input wiring, the UMI-7764 has a 10-position terminal block. This terminal block provides access to the four breakpoint outputs and the four trigger inputs. Refer to Figure 1 to help you locate the breakpoint output/trigger input terminal block on your UMI-7764 accessory. See Figure 9 for more information on breakpoint output and trigger input wiring.

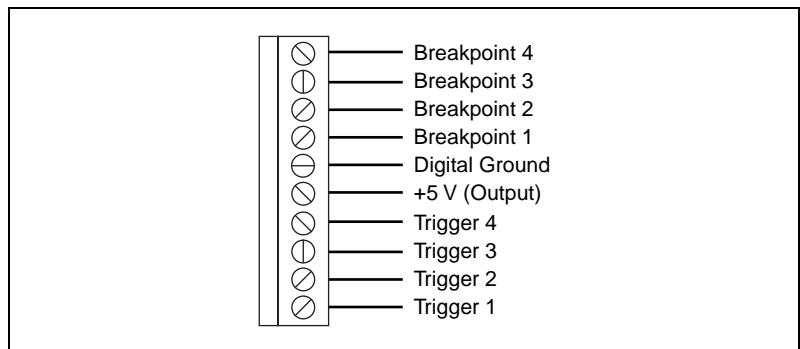

**Figure 9.** UMI-7764 Breakpoint/Trigger Terminal Block Pin Assignments

## Shutdown/Inhibit All Terminal Block

The UMI accessory has a 4-position terminal block for shutdown and inhibit all wiring. Refer to Figure 1 to help you locate the shutdown/inhibit all terminal block on your UMI-7764 accessory. See Figure 10 for more information on shutdown/inhibit all wiring.

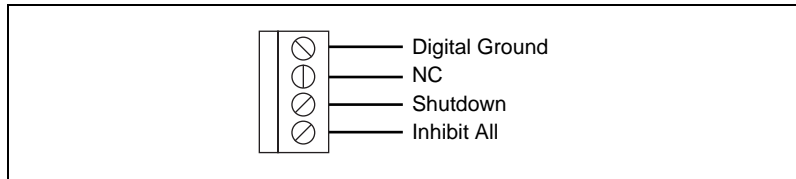
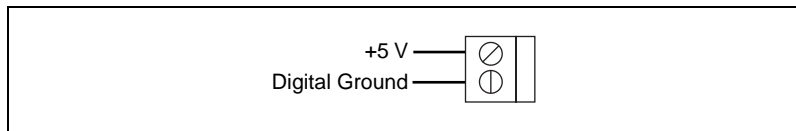

**Figure 10.** Shutdown/Inhibit All Terminal Block Pin Assignments

The Inhibit All signal acts as a global inhibit, and, when asserted, activates the Inhibit Outputs. The Inhibit All signal includes a 3.3 k $\Omega$  pull-up resistor on its input. The Shutdown signal is passed through to the motion controller and is typically used to disable the controller.

## Power Input Terminal Block

The UMI-7764 has a 2-position terminal block for wiring power to the unit. Refer to Figure 1 to help you locate the power input terminal block on your UMI-7764 accessory. Figure 11 shows the 2-position terminal block pinout.



**Figure 11.** 2-Position Power Input Terminal Block Pin Assignment



**Note** To properly operate your UMI-7764 accessory, you must supply a +5 V source to the power input terminal block.



**Note** The +5 V power is redistributed to other terminal blocks as an output power source.

# UMI-7764 Specifications

---

The following specifications apply only to the UMI-7764 accessory. To obtain a system specification, you must account for your motion controller. Please refer to your controller specifications to determine overall system specifications.

Some signals have compatibility defined as signal pass-through. This means the UMI-7764 may have passive filtering on these signals but will not affect the voltage range or current handling capability. Consult your motion controller specifications to determine the allowable voltage range and logic level compatibility of the signal.

These specifications are typical at 25 °C unless otherwise specified. Refer to your motion controller user manual for detailed specifications on encoder inputs, limit and home switch inputs, breakpoint outputs, trigger inputs, and analog inputs.

## Encoder Interface (Each Axis)

Inputs.....	Quadrature, incremental
Differential input threshold.....	$\pm 0.3$ V (typical)
Single-ended input threshold .....	TTL/CMOS
Voltage range .....	0 to 5 VDC
Noise filter (RC time constant) .....	100 ns
Max quadrature frequency .....	1 MHz

## Limit and Home Switch Inputs (Each Axis)

Noise filter (RC time constant) .....	10 $\mu$ s
Compatibility .....	Signal pass-through

## Trigger Inputs

Noise filter (RC time constant) .....	100 ns
Compatibility .....	Signal pass-through

## Inhibit and Inhibit All Inputs

Voltage range.....	0 to 12 VDC
Input voltage threshold .....	TTL/CMOS
Input pull-up resistor .....	3.3 k $\Omega$
Compatibility .....	Signal pass-through

## Analog Inputs

Noise filter (RC time constant).....	10 $\mu$ s
Compatibility .....	Signal pass-through

## Axis Inhibit Out

Voltage range.....	0 to 5 VDC
Output low voltage .....	0.5 V at 16 mA
Output high voltage .....	2.4 V at 3.2 mA

## Operating Environment

Temperature.....	0 to 55 $^{\circ}$ C
Storage temperature .....	-20 to 70 $^{\circ}$ C
Relative humidity .....	10 to 90% (noncondensing)

## Power Requirements

+5 VDC.....	0.2 amps + user-defined encoder and limit power
-------------	--

## Host Bus Voltage Interlock

Voltage.....	5 VDC $\pm$ 5%
--------------	----------------

## Physical

Dimensions .....	19.5 by 15.2 by 4.5 cm (7.7 by 6.0 by 1.8 in.)
------------------	---

# UMI-4A

This section describes the UMI-4A terminal block. Refer to Figure 12 to help you locate the different parts of the UMI-4A accessory.

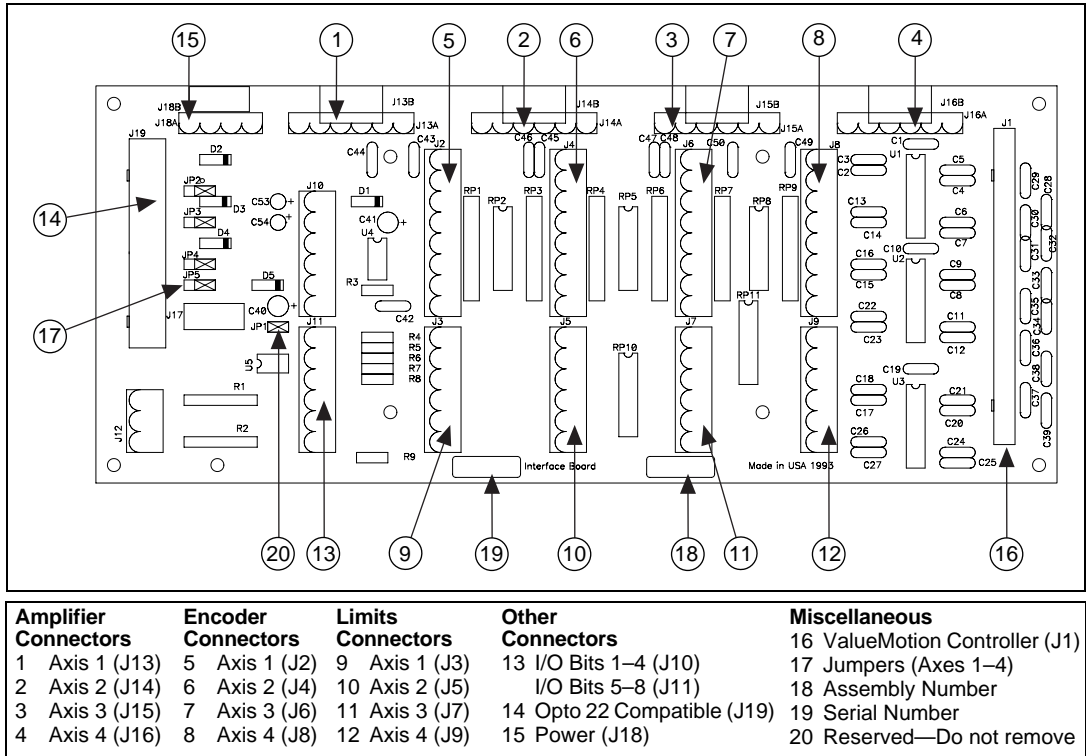

Figure 12. UMI-4A Parts Locator Diagram

## Amplifier/Driver Terminal Block

For amplifier/driver wiring, each UMI-4A axis has a separate 6-position terminal block. Refer to Figure 12 to help you locate the amplifier/driver terminal block on your UMI-4A accessory. Figure 13 shows the terminal block pin assignment for the UMI-4A amplifier/driver used with a servo board.

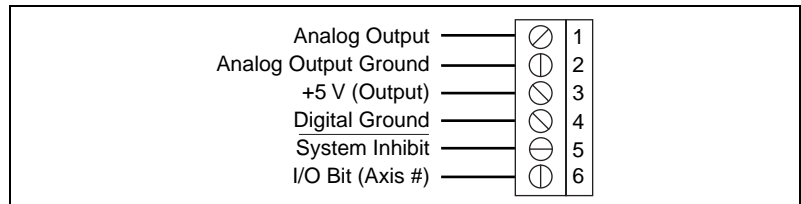
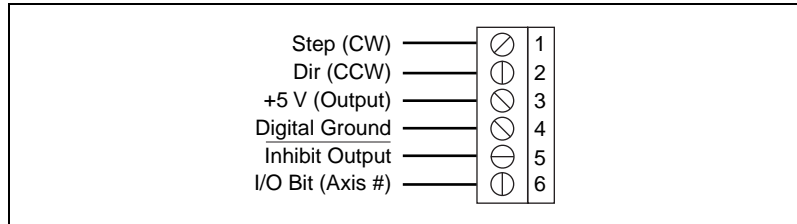

Figure 13. UMI-4A Amplifier/Driver with Servo Terminal Block Pin Assignment

The analog output signals are used as command outputs to a servo amplifier. The System Inhibit output signals are used to disable all of the amplifiers. The UMI accessory combines the host bus interlock circuit and the Enable Input signals to create the global System Inhibit signals. The host bus interlock monitors the +5 V pin from the motion controller to verify that the controller is powered and properly connected to the UMI. If the host bus interlock detects a problem, or if both Enable Input signals are deasserted, the System Inhibit signals are asserted.

Figure 14 shows the UMI-4A amplifier/driver terminal block pin assignment used with a stepper board.



**Figure 14.** UMI-4A Amplifier/Driver with Stepper Terminal Block Pin Assignment

The Step and Dir signals are used as command outputs to a stepper driver. The Inhibit Output signals are used to disable the driver for that axis. The UMI accessory combines the host bus interlock circuit, the Enable Input signals, and the per axis controller Inhibit Output to create the per axis Inhibit Output signal. If the voltage drops to the host bus interlock circuit, if both Enable Inputs are deasserted, or if the controller Inhibit Output for that axis is asserted, the Inhibit Output signal for that axis is asserted.

To configure your UMI-4A accessory for servo, move all four jumpers to the right. To configure your accessory for stepper, move all four jumpers to the left. See Figure 15 for more information on configuring your UMI-4A jumpers. Refer to Figure 12 to help you locate the jumpers on your UMI-4A accessory.

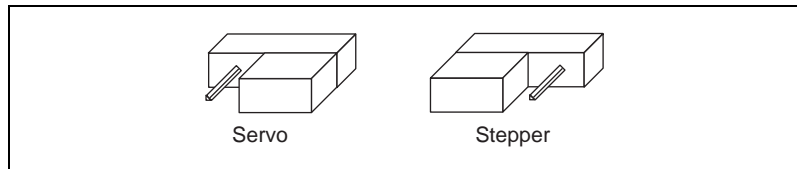

**Figure 15.** UMI-4A Jumper Configuration

## Encoder Terminal Block

For incremental encoder connections, each UMI-4A axis has a separate 8-position terminal block. UMI-4A accepts either single-ended TTL or differential line driver inputs. You can connect open-collector encoders to the UMI-4A accessory by installing a 2.2 k $\Omega$  pull-up resistor to +5 V.



**Note** Encoders with line driver outputs are recommended for all applications and must be used if the encoder cable length is greater than 10 feet.

Power for the encoders is internally routed from the power input terminal block and is available on pin 7 (+5 V). You must supply a +5 V source to the power input terminal block for proper operation. Refer to Figure 12 to help you locate the encoder terminal blocks on your UMI-4A accessory. Figure 16 shows the wiring for the differential encoder.



**Note** The dotted loop indicates a shielded cable.

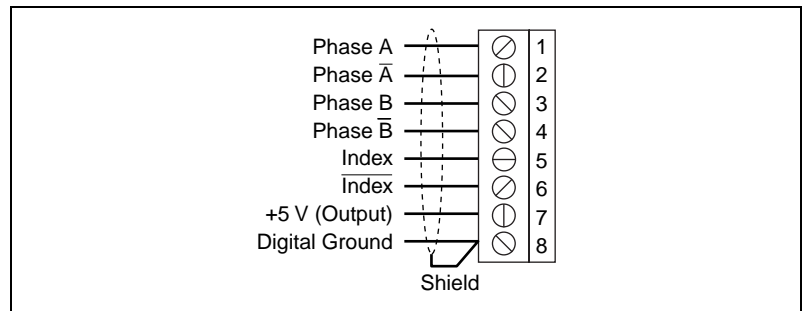

**Figure 16.** Differential Encoder Wiring

Figure 17 shows the wiring for the single-ended encoder.

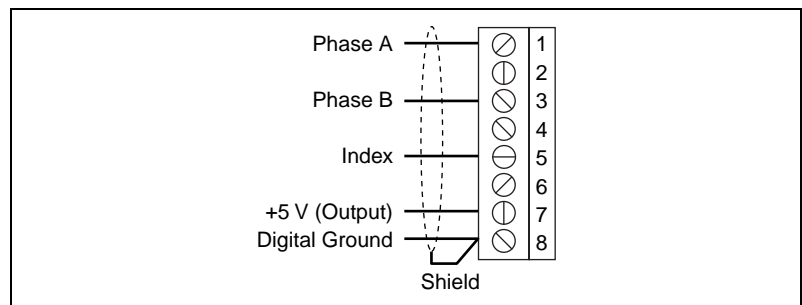

**Figure 17.** Single-Ended Encoder Wiring

The UMI-4A accessory allows for differential inputs for Phase A, Phase B, and Index signals. You can easily accommodate encoders with phase relationships different from Figure 18 by swapping the signals as required by the specific application. The Index pulse must occur when both Phase A and Phase B signals are logic low as shown in Figure 7. Servo and closed-loop stepper applications require encoder feedback and consistent directional polarity between the motor and encoder for stable operation. The UMI-4A uses the following standards for motor direction:

- Positive = forward = Clockwise (CW) facing motor shaft
- Negative = reverse = Counter-clockwise (CCW) facing motor shaft

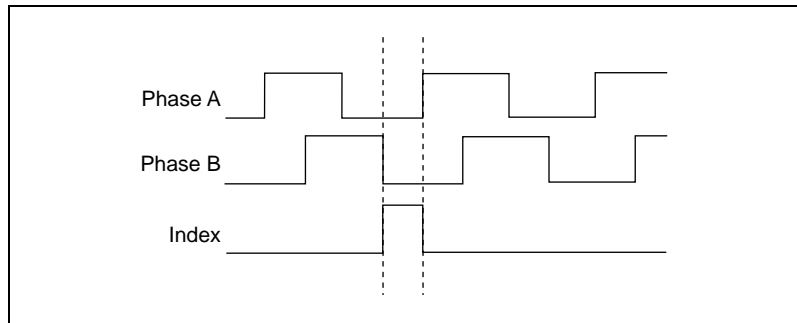

**Figure 18.** Encoder Signal Phasing—CW Rotation

The encoder inputs are filtered by both analog and digital noise filters. You must use cables with twisted pairs and an overall shield for improved noise immunity. When connecting the encoder to the UMI-4A, you should use at least 24-AWG wire.



**Caution** Using an unshielded cable allows noise to corrupt the encoder signals, which results in lost counts, reduced accuracy, and other erroneous encoder and controller operations.

## Limit Switch Terminal Block

For forward and reverse limit and home switch connections, each UMI-4A has a separate 6-position terminal block per axis. All limit and home switch inputs are filtered on the UMI-4A to enhance noise immunity.

The UMI-4A supports active and passive limit switches. You can use auxiliary VDC on pin 4 to power active, open-collector limit switches. To use the auxiliary VDC you must supply a voltage to the auxiliary VDC input (pin 2 of the power input terminal block). Refer to Figure 12 to help you locate the limit switch terminal block on your UMI-4A accessory. Figure 19 shows an example of a passive limit switch terminal block pinout.

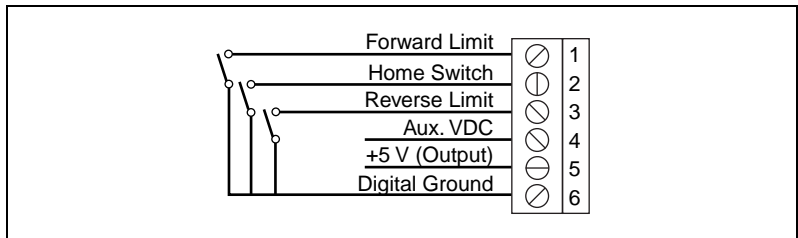

**Figure 19.** UMI-4A Limit Switch Terminal Block Pin Assignment (Passive Limit Switch Connection Example)

## Digital I/O Terminal Blocks

The UMI-4A has two I/O connectors: a 34-pin male box header (J19), which is compatible with standard Opto 22 I/O racks, and two 6-pin removable screw terminal blocks (J10 and J11) for all other I/O configurations. You can use both I/O configurations separately or in parallel.

Pin 5 of each terminal block (J10 and J11) is an Enable Input connection. This connection controls a system enable–system inhibit function. If your configuration uses the inhibit output signal available on each per-axis driver/amplifier terminal block, the enable input on J10 or J11 must be connected to the common (ground) signal to enable the driver/amplifier.



**Note** You do not need to duplicate the switch on both J10 and J11; use only one or the other for the Enable Input.

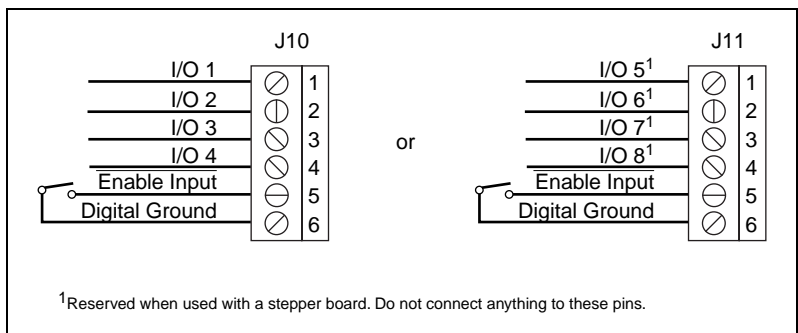

**Figure 20.** Using Available Pins On J10 and J11



**Caution** If you connect the enable input to the common signal and bypass the enable/disable function, you need to provide enable/disable control of the drivers/amplifiers elsewhere in the system.

Figure 21 shows the 34-pin Opto 22 compatible connector.

N/C	1	2	Digital Ground
N/C	3	4	Digital Ground
N/C	5	6	Digital Ground
N/C	7	8	Digital Ground
N/C	9	10	Digital Ground
N/C	11	12	Digital Ground
N/C	13	14	Digital Ground
N/C	15	16	Digital Ground
I/O Bit 8	17	18	Digital Ground
I/O Bit 7	19	20	Digital Ground
I/O Bit 6	21	22	Digital Ground
I/O Bit 5	23	24	Digital Ground
I/O Bit 4	25	26	Digital Ground
I/O Bit 3	27	28	Digital Ground
I/O Bit 2	29	30	Digital Ground
I/O Bit 1	31	32	Digital Ground
N/C	33	34	Digital Ground

**Figure 21.** 34-Pin Opto 22 Compatible Connector Pin Assignment

## Power Input Terminal Block

The UMI-4A has a 4-position terminal block for wiring power to the unit. Refer to Figure 12 to help you locate the power input terminal block on your UMI-4A accessory. Figure 11 shows the 4-position terminal block pinout.

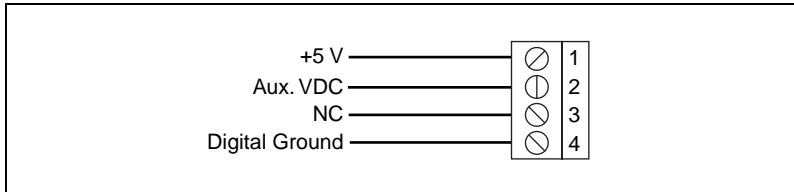

**Figure 22.** 4-Position Power Input Terminal Block Pin Assignment



**Note** To properly operate your UMI-4A accessory, you must supply a +5 V source to the power input terminal block.



**Note** The auxiliary VDC input on the power input terminal block is optional and is redistributed to other terminal blocks as an output power source.

# UMI-4A Specifications

---

The following specifications apply only to the UMI-4A accessory. To obtain a system specification, you must account for your motion controller. Please refer to your controller specifications to determine overall system specifications.

Some signals have compatibility defined as signal pass-through. This means the UMI-4A may have passive filtering on these signals but will not affect the voltage range or current handling capability. Consult your motion controller specifications to determine the allowable voltage range and logic level compatibility of the signal.

These specifications are typical at 25 °C unless otherwise specified. Refer to your motion controller user manual for detailed specifications on encoder inputs, limit and home switch inputs, breakpoint outputs, trigger inputs, and analog inputs.

## Encoder Interface (Each Axis)

Inputs.....	Quadrature, incremental
Differential input threshold .....	$\pm 0.3$ V (typical)
Single-ended input threshold .....	TTL/CMOS
Voltage range .....	0 to 5 VDC
Noise filter (RC time constant) .....	100 ns
Max quadrature frequency .....	1 MHz

## Limit and Home Switch Inputs (Each Axis)

Noise filter (RC time constant) .....	10 $\mu$ s
Compatibility .....	Signal pass-through

## Configurable I/O

Compatibility .....	Signal pass-through
Opto 22 compatible .....	via J19 connector

## Operating Environment

Temperature .....	0 to 55 °C
Storage temperature .....	-20 to 70 °C
Relative humidity .....	10 to 90% (noncondensing)

## Power Requirements

+5 VDC.....	0.2 A + user-defined encoder power
Aux. VDC.....	User-defined limit switch power

## Host Bus Voltage Interlock

Voltage.....	5 VDC $\pm$ 5%
--------------	----------------

## Physical

Dimensions .....	23.62 by 10.03 cm (9.3 by 3.95 in.) Universal DIN-rail base (supplied)
------------------	---

# UMI-Flex6

This section describes the UMI-Flex6 terminal block. Refer to Figure 23 to help you locate the different parts of the UMI-Flex6 accessory.

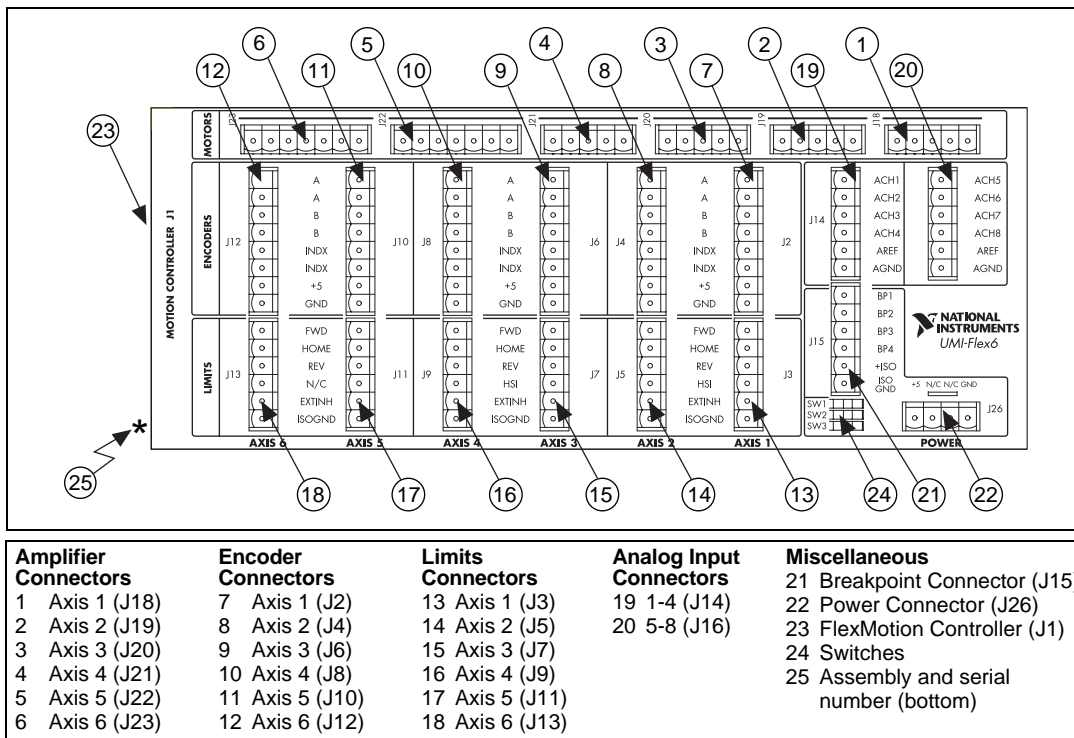
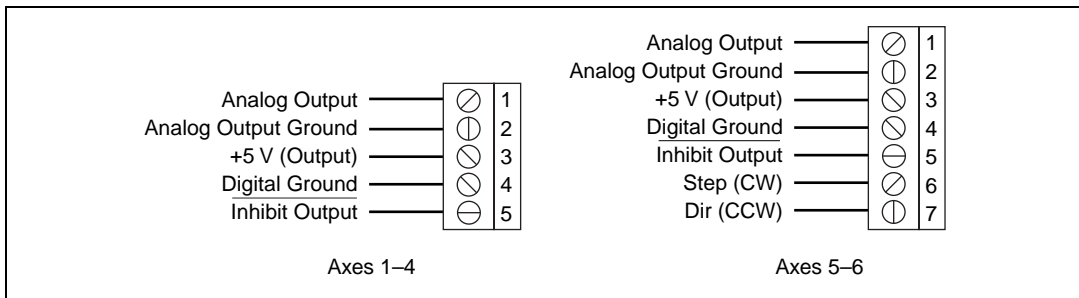

Figure 23. UMI-Flex6 Parts Locator Diagram

## Amplifier/Driver Terminal Block

For amplifier/driver wiring, each UMI-Flex6 axis has a separate 5- or 7-position terminal block. Refer to Figure 23 to help you locate the amplifier/driver terminal blocks on your UMI-Flex6 accessory. Figure 24 shows the UMI-Flex6 amplifier/driver terminal block pin assignment for the servo and combined servo/stepper axes. The 5-position UMI-Flex6 terminal block supports the servo axes, and the 7-position terminal block adds stepper support.



**Figure 24.** UMI-Flex6 Axes Amplifier/Driver Terminal Block Pin Assignments

The Analog Output signals are used as command outputs to a servo amplifier or as general-purpose voltage outputs. The Step and Dir signals are used as command outputs to a stepper driver.

The Inhibit Output signals are used to disable the amplifier/driver for that axis. The UMI combines the host bus interlock circuit, the Inhibit Input signals, and the per axis controller Inhibit Output to create the per axis Inhibit Output signal. The host bus interlock monitors the +5 V pin from the motion controller to verify that the controller is powered and properly connected to the UMI. If the host bus interlock detects a problem, or if any Inhibit Input signal is asserted, or the controller Inhibit Output signal for that axis is asserted, the Inhibit Output for that axis is asserted.

You can configure the Axis Inhibit Out signal as active-low or active-high outputs using switch SW2. Setting SW2 to the right configures the signal as active-low; setting SW2 to the left configures the signal as active-high.



**Note** You must configure the controller's Inhibit Output signals as active low for proper operation of the inhibit circuitry.

## Encoder Terminal Block

For incremental encoder connections, each UMI-Flex6 axis has a separate 8-position terminal block. UMI-Flex6 accepts either single-ended TTL or differential line driver inputs. You can connect open-collector encoders to the UMI-Flex6 accessory by installing a 2.2 k $\Omega$  pull-up resistor to +5 V.



**Note** Encoders with line driver outputs are recommended for all applications and must be used if the encoder cable length is greater than 10 feet.

Power for the encoders is internally routed from the power input terminal block and is available on pin 7 (+5 V). You must supply a +5 V source to the power input terminal block for proper operation. Refer to Figure 23 to help you locate the encoder terminal blocks on your UMI-Flex6 accessory. Figure 25 shows the wiring for the differential encoder.



**Note** The dotted loop indicates a shielded cable.

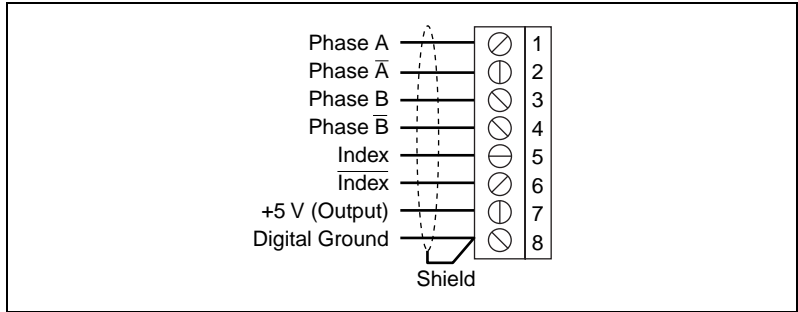

**Figure 25.** Differential Encoder Wiring

Figure 26 shows the wiring for the single-ended encoder.

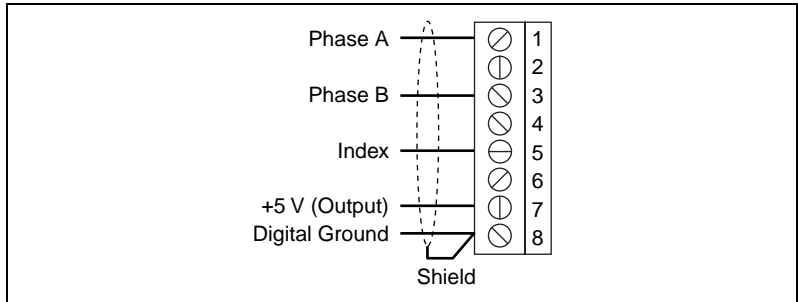

**Figure 26.** Single-Ended Encoder Wiring

The UMI-Flex6 accessory allows for differential inputs for Phase A, Phase B, and Index signals. You can easily accommodate encoders with phase relationships different from Figure 27 by swapping the signals as required by the specific application. The Index pulse must occur when both Phase A and Phase B signals are logic low as shown in Figure 27. Servo and closed-loop stepper applications require encoder feedback and consistent directional polarity between the motor and encoder for stable operation. The UMI-Flex6 uses the following standards for motor direction:

- Positive = forward = Clockwise (CW) facing motor shaft
- Negative = reverse = Counter-clockwise (CCW) facing motor shaft

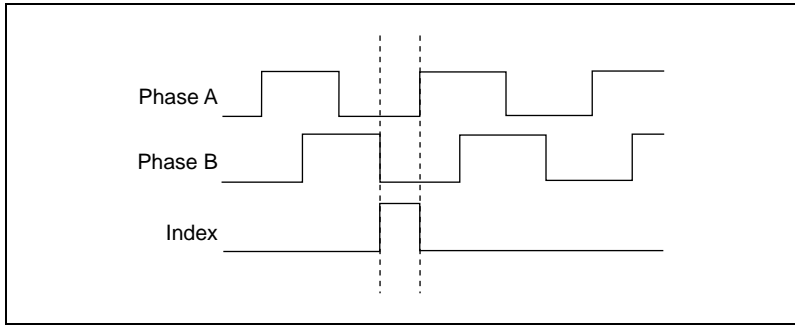

**Figure 27.** Encoder Signal Phasing—CW Rotation

The encoder inputs are filtered by both analog and digital noise filters. You must use cables with twisted pairs and an overall shield for improved noise immunity. When connecting the encoder to the UMI-Flex6, you should use at least 24-AWG wire.



**Caution** Using an unshielded cable allows noise to corrupt the encoder signals, which results in lost counts, reduced accuracy, and other erroneous encoder and controller operations.

## Limit Switch Terminal Block

For Forward and Reverse Limit and Home Input switch connections, each UMI-Flex6 axis has a separate 6-position terminal block. All limit and home switch inputs are connected to the Opto-coupled inputs on the FlexMotion board. Refer to Figure 23 to help you locate the limit switch terminal block on your UMI-Flex6 accessory. See Figure 28 for the UMI-Flex6 limit switch terminal block pinout.

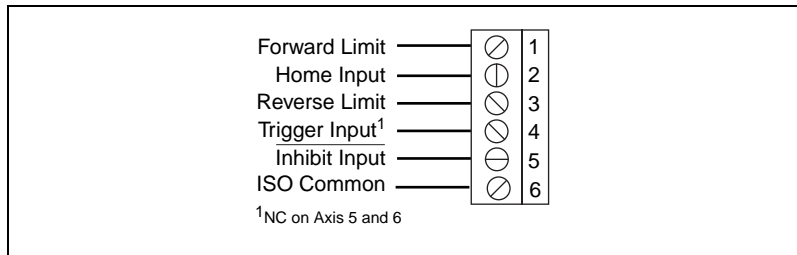

**Figure 28.** UMI-Flex6 Limit Switch Terminal Block Pin Assignment

You can configure the functionality of the Inhibit Inputs using switches SW1 and SW3. These inputs can be configured as a group as active low global inhibits or as active high global E-Stops. When configured as global inhibits, an active low signal applied to any input asserts the inhibit output lines on the UMI. When configured as global E-Stops, an active high signal applied to any input asserts the inhibit output lines on the UMI and asserts the E-Stop signal back to the FlexMotion controller. See Table 1 for switch SW1 and SW3 settings.

**Table 1.** Inhibit Input Configuration

SW1	SW3	Inhibit Input Configuration
Right	Right	Enable active low global inhibits
Left	Left	Enable active high global E-Stops
Left	Right	Disable active high global E-Stops*
Right	Left	Reserved, do not select.

\* This grounds the input signal on the board. Do not connect a source to the input pin that cannot tolerate a short to ground.

## Analog Input Terminal Blocks

For analog input wiring, the UMI-Flex6 has two, 6-position terminal blocks. Each connector provides access to four of the eight analog input channels on the FlexMotion boards. Refer to Figure 23 to help you locate the analog input terminal blocks on your UMI-Flex6 accessory. See Figures 29 and 30 for analog input terminal block pinout information.

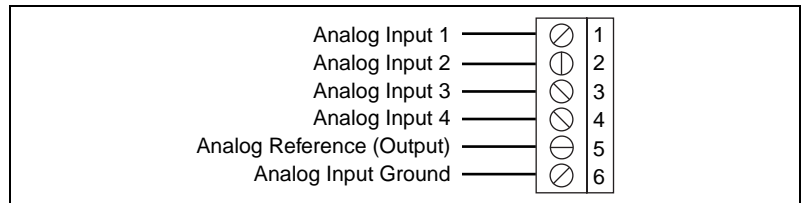

**Figure 29.** UMI-Flex6 Analog Input Channels 1 through 4

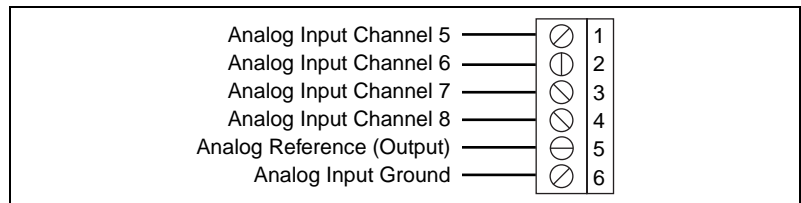

**Figure 30.** UMI-Flex6 Analog Input Channels 5 through 8

## Breakpoint Output Terminal Block

For breakpoint output wiring, the UMI-Flex6 has a 6-position terminal block. This terminal block also provides access to the four breakpoint outputs as well as the isolated voltage input. See Figure 31 for more information on breakpoint output and isolated voltage input wiring.

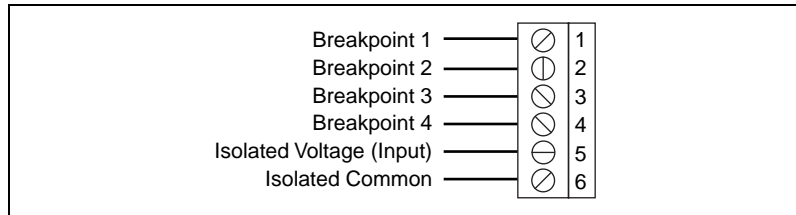

**Figure 31.** UMI-Flex6 Breakpoint Output Channels 1 through 4

The opto-couplers on the FlexMotion board can be powered either from an external source or from the FlexMotion board itself. If you want to use an external source for the isolated voltage, you must configure the FlexMotion board for this setting prior to connecting the external source.



**Caution** Failure to configure the board properly for an external power source may damage your UMI and FlexMotion board.

## Power Input Terminal Block

The UMI-Flex6 has a 4-position terminal block for wiring power to the unit. Refer to Figure 23 to help you locate the power input terminal block on your UMI-Flex6 accessory. Figure 32 shows the 4-position terminal block pinout.

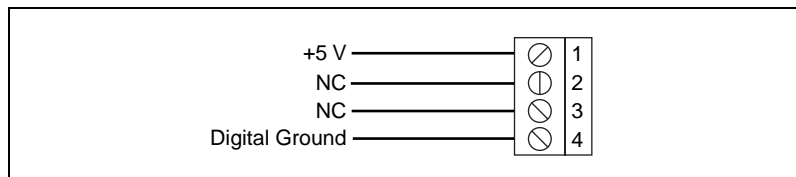

**Figure 32.** 4-Position Power Input Terminal Block Pin Assignment



**Note** To properly operate your UMI-Flex6 accessory, you must supply a +5 V source to the power input terminal block.



**Note** The +5 V power is redistributed to other terminal blocks as an output power source.

# UMI-Flex6 Specifications

---

The following specifications apply only to the UMI-Flex6 accessory. To obtain a system specification, you must account for your motion controller. Please refer to your controller specifications to determine overall system specifications.

These specifications are typical at 25 °C unless otherwise specified. Refer to your motion controller user manual for detailed specifications on encoder inputs, limit and home switch inputs, high speed inputs, breakpoint outputs, and analog inputs.

## Axis Inhibit Out

Voltage range ..... 0 to 5 VDC

Output current ..... 16 mA sink max.

## Operating Environment

Temperature ..... 0 to 55 °C

Storage temperature ..... -20 to 70 °C

Relative humidity ..... 10 to 90% (noncondensing)

## Power Requirements

+5 VDC ..... 0.2 A + user-defined encoder and  
limit power

## +ISO

Voltage ..... 5 to 24 VDC

Current ..... User-defined isolated signals

## Host Bus Voltage Interlock

Voltage ..... 5 VDC  $\pm$  5%

## Physical

Dimensions..... 26.67 by 11.18 cm  
(10.5 by 4.4 in)

# UMI-Flex4

This section describes the UMI-Flex4 terminal block. Refer to Figure 33 to help you locate the different parts of the UMI-Flex4 accessory.

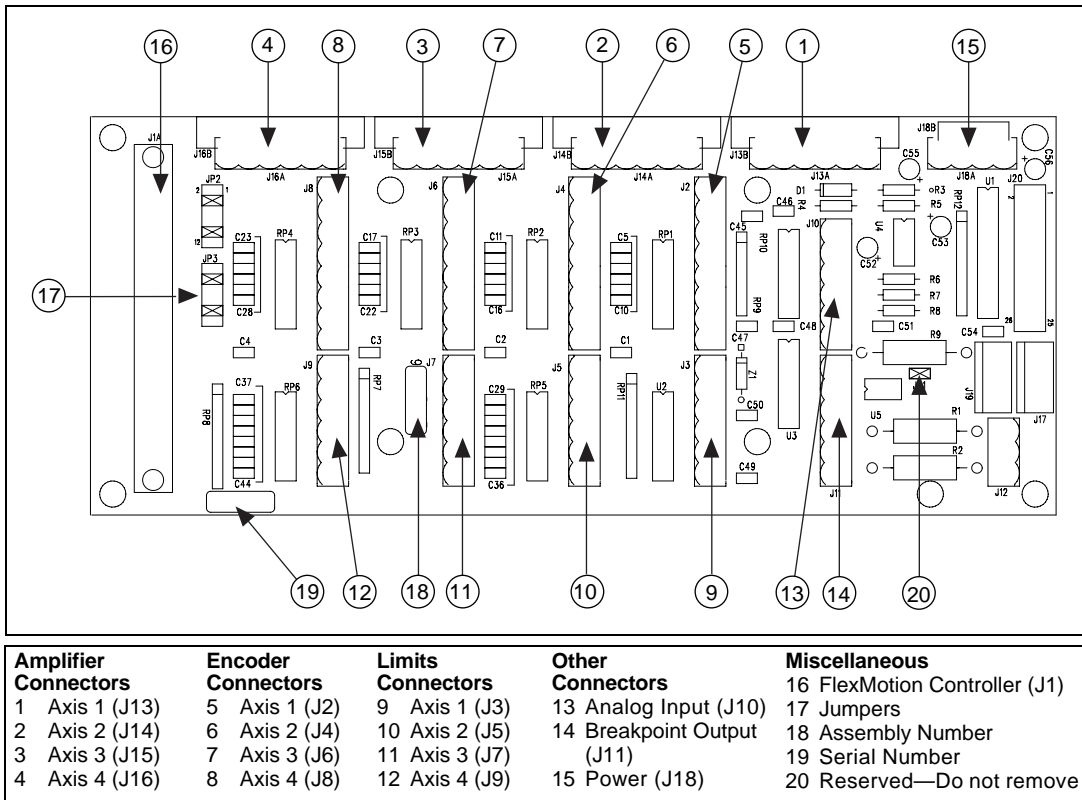
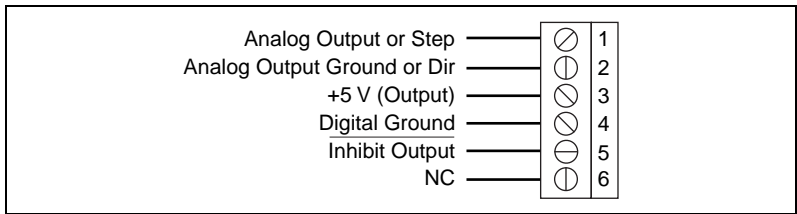

Figure 33. UMI-Flex4 Parts Locator Diagram

## Amplifier/Driver Terminal Block

For amplifier/driver wiring, the UMI-Flex4 has four separate 6-position terminal blocks. Figure 34 shows a UMI-Flex4 terminal block pin assignment. The first two terminal blocks (items 1 and 2 in Figure 33) are dedicated to servo axes 1 and 2. The third terminal block (item 3 in Figure 33) is jumper configurable to support servo axes 3 and 5 and stepper axis 5. The fourth terminal block (item 4 in Figure 33) is jumper configurable to support servo axes 4 and 6 and stepper axis 6. See Figure 35 for more information on configuring these jumpers.



**Figure 34.** UMI-Flex4 Axes Amplifier/Driver Terminal Block Pin Assignment

The Analog Output signals are used as command outputs to a servo amplifier or as general-purpose voltage outputs. The Step and Dir signals are used as command outputs to a stepper driver.

The Inhibit Output signals are used to disable the amplifier/driver for that axis. The UMI combines the host bus interlock circuit, the per axis Inhibit Input signals, and the per axis controller Inhibit Output to create the per axis Inhibit Output signal. The host bus interlock monitors the +5 V pin from the motion controller to verify that the controller is powered and properly connected to the UMI. If the host bus interlock detects a problem, or if the Inhibit Input signal or the controller Inhibit Output signal for that axis is asserted, the Inhibit Output for that axis is asserted.



**Note** You must configure the controller's Inhibit Output signals as active-low for proper operation of the inhibit circuitry.

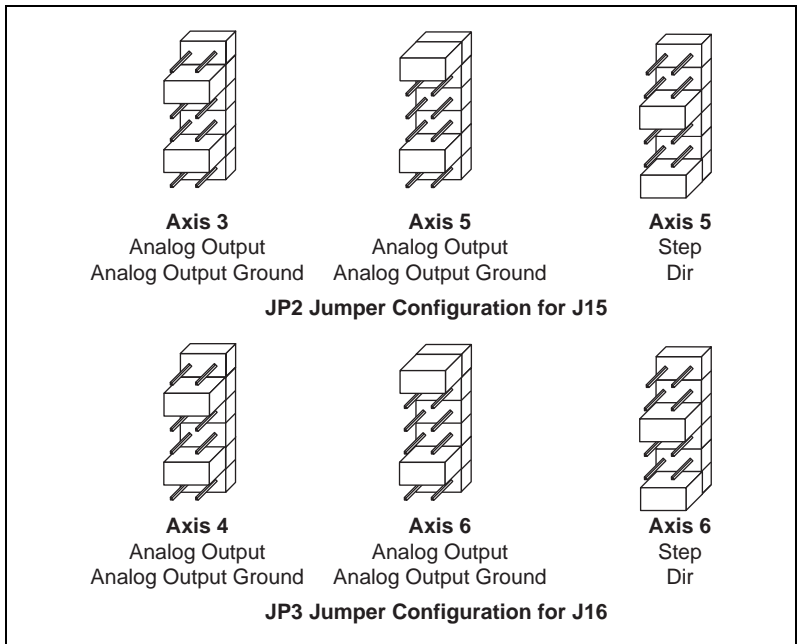

**Figure 35.** UMI-Flex4 Jumper Configuration

# Encoder Terminal Block

For incremental encoder connections, each UMI-Flex4 axis has a separate 8-position terminal block. UMI-Flex4 accepts either single-ended TTL or differential line driver inputs. You can connect open-collector encoders to the UMI-Flex4 accessory by installing a 2.2 kΩ pull-up resistor to +5 V.



**Note** Encoders with line driver outputs are recommended for all applications and must be used if the encoder cable length is greater than 10 feet.

Power for the encoders is internally routed from the power input terminal block and is available on pin 7 (+5 V). You must supply a +5 V source to the power input terminal block for proper operation. Refer to Figure 33 to help you locate the encoder terminal blocks on your UMI-Flex4 accessory. Figure 36 shows the wiring for the differential encoder.



**Note** The dotted loop indicates a shielded cable.

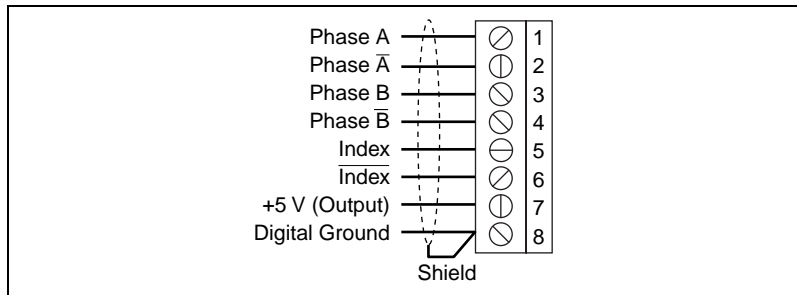

**Figure 36.** Differential Encoder Wiring

Figure 37 shows the wiring for the single-ended encoder.

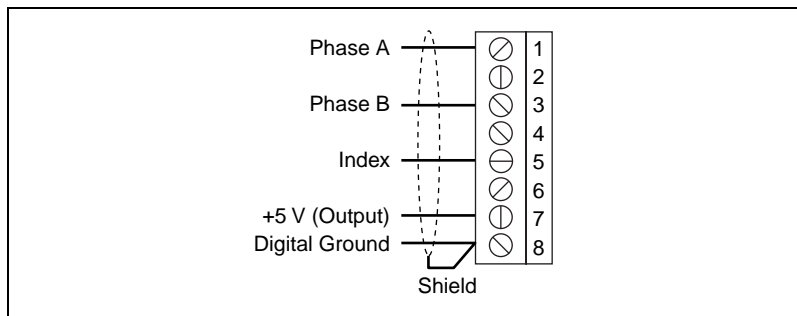

**Figure 37.** Single-Ended Encoder Wiring

The UMI-Flex4 accessory allows for differential inputs for Phase A, Phase B, and Index signals. You can easily accommodate encoders with phase relationships different from Figure 38 by swapping the signals as required by the specific application. The Index pulse must occur when both Phase A and Phase B signals are logic low as shown in Figure 38. Servo and closed-loop stepper applications require encoder feedback and consistent directional polarity between the motor and encoder for stable operation. The UMI-Flex4 uses the following standards for motor direction:

- Positive = forward = Clockwise (CW) facing motor shaft
- Negative = reverse = Counter-clockwise (CCW) facing motor shaft

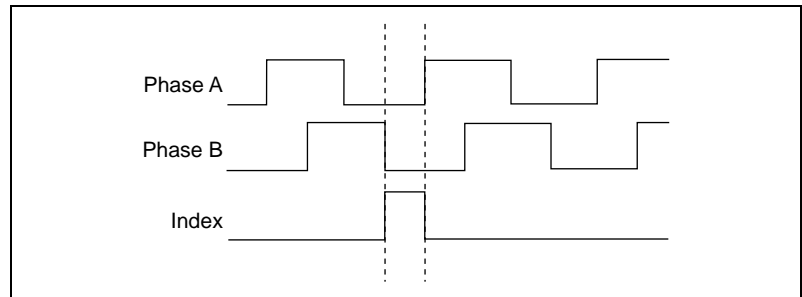

**Figure 38.** Encoder Signal Phasing—CW Rotation

The encoder inputs are filtered by both analog and digital noise filters. You must use cables with twisted pairs and an overall shield for improved noise immunity. When connecting the encoder to the UMI-Flex4, you should use at least 24-AWG wire.



**Caution** Using an unshielded cable allows noise to corrupt the encoder signals, which results in lost counts, reduced accuracy, and other erroneous encoder and controller operations.

## Limit Switch Terminal Block

For Forward and Reverse Limit and Home Input switch connections, the UMI-Flex4 accessory has a separate 6-position terminal block per axis. All limit and home switch inputs are connected to the opto-coupled inputs on the FlexMotion board. Refer to Figure 33 to help you locate the limit switch terminal block on your UMI-Flex4 accessory. See Figure 39 for the UMI-Flex4 limit switch terminal block pinout.

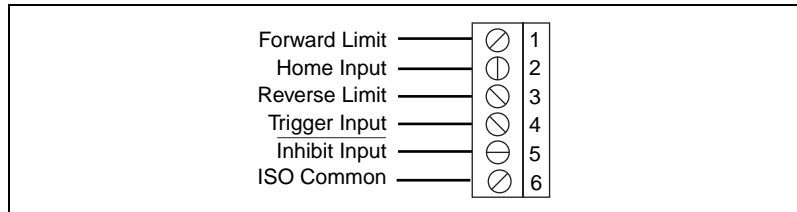

**Figure 39.** UMI-Flex4 Limit Switch Terminal Block Pin Assignment

## Analog Input Terminal Block

For analog input wiring, the UMI-Flex4 has one, 6-position terminal block. The connector provides access to four of the eight analog input channels on the FlexMotion boards. Refer to Figure 33 to help you locate the analog input terminal blocks on your UMI-Flex4 accessory. See Figure 40 for analog input terminal block pinout information.

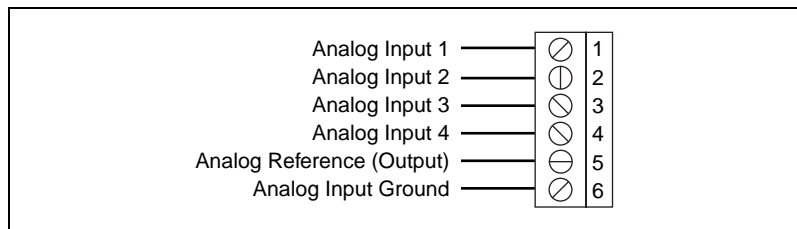

**Figure 40.** UMI-Flex4 Analog Input Channels 1 through 4

## Breakpoint Output Terminal Block

For breakpoint output wiring, the UMI-Flex4 has a 6-position terminal block. This terminal block also provides access to the four breakpoint outputs as well as the isolated voltage input. See Figure 41 for more information on breakpoint output and isolated voltage input wiring.

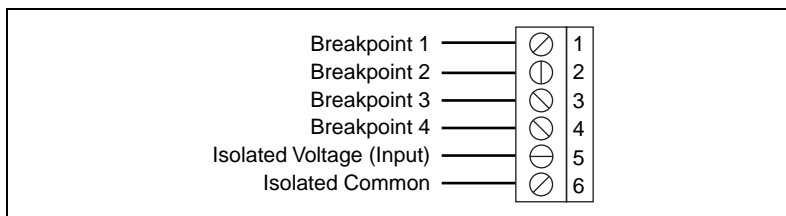

**Figure 41.** UMI-Flex4 Breakpoint Output Channels 1 through 4

The opto-couplers on the FlexMotion board can be powered either from an external source or from the FlexMotion board itself. If you want to use an external source for the isolated voltage, you must configure the FlexMotion board for this setting prior to connecting the external source.



**Caution** Failure to configure the board properly for an external power source may damage your UMI and FlexMotion board.

## Power Input Terminal Block

The UMI-Flex4 has a 4-position terminal block for wiring power to the unit. Refer to Figure 33 to help you locate the power input terminal block on your UMI-Flex4 accessory. Figure 42 shows the 4-position terminal block pinout.

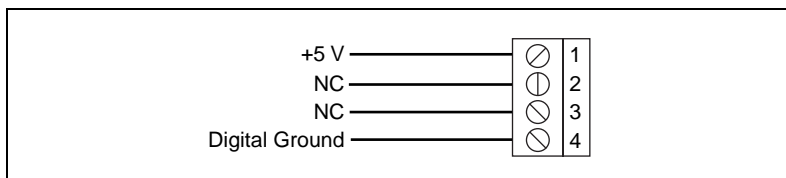

**Figure 42.** 4-Position Power Input Terminal Block Pin Assignment



**Note** To properly operate your UMI-Flex4 accessory, you must supply a +5 V source to the power input terminal block.



**Note** The +5 V power is redistributed to other terminal blocks as an output power source.

# UMI-Flex4 Specifications

---

The following specifications apply only to the UMI-Flex4 accessory. To obtain a system specification, you must account for your motion controller. Please refer to your controller specifications to determine overall system specifications.

These specifications are typical at 25 °C unless otherwise specified. Refer to your motion controller user manual for detailed specifications on encoder inputs, limit and home switch inputs, high speed inputs, breakpoint outputs, and analog inputs.

## Axis Inhibit Out

Voltage range.....0 to 5 VDC  
Output current.....16 mA sink max.

## Operating Environment

Temperature.....0 to 55 °C  
Storage temperature.....-20 to 70 °C  
Relative humidity .....10 to 90% (noncondensing)

## Power Requirements

+5 VDC.....0.2 A + user-defined encoder power

## +ISO

Voltage.....5 to 24 VDC  
Current.....User-defined isolated signals

## Host Bus Voltage Interlock

Voltage.....5 VDC ± 5%

## Physical

Dimensions .....23.62 by 10.03 cm  
(9.3 by 3.95 in.)  
Universal DIN-rail base  
(supplied)



321941B-01

Aug99